

China National High tech Enterprise  
China Specialized And Innovative Enterprise



**DELI ASSISTANT,  
YOUR BEST ASSISTANT IN TEA INDUSTRY !**



Market demand oriented, innovation and efficiency improvement as our mission!  
 Main Products : Tea Garden Management Equipment, Tea Processing Equipment, Tea processing Lines, Tea Fine Cleaning Equipments, Tea Packaging Equipments.

2008Y - 07M : QUANZHOU DELI AGROFORESTRAL MACHINERY CO LTD was established

2009Y - 05M : The tea picking machine has been included in the subsidy catalog of the Chinese Ministry of Agriculture

2010Y - 04M Backpack power spray product was approved by Fujian Provincial Science and Technology Department for SME Innovation Fund

2011Y - 12M The DELI ASSISTANT trademark has been recognized as a well-known trademark

2013Y - 06M Our first tea primary processing machine was exported to India

2017Y - 12M Split the garden machinery department and establish a joint-stock company called "FUJIAN GUANNENG MACHINERY CO LTD"

2019Y - 04M AND 2022Y 04M Our company has become the winning bidder in the bidding of the Ministry of Agriculture of Georgia

2020Y - 05M Split the packaging part and establish a joint-stock company called "QUANZHOU MULIN Machinery CO LTD"

2021Y - 06M Our company has become the winning bidder in the bidding of the Peruvian Ministry of Agriculture

2022Y - 12M Our company has been rated as a national high-tech enterprise

2023Y - 03M Our company has become a graduate workstation at Huaqiao University

2023Y - 06M Our company has become the winning bidder in the bidding of the Vietnamese Ministry of Agriculture

2023Y - 10M Our company has become a supplier of tea machinery to the University of Georgia in the United States

2024Y - Our company has obtained the Chinese National Innovative Enterprise Certificate

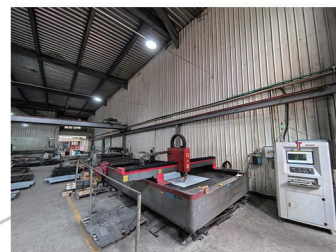

# 茶园管理设备

## TEA GARDEN MANAGEMENT EQUIPMENTS



## Battery Tea Leaf Harvester (Backpack Battery)

|                  |                  |                  |
|------------------|------------------|------------------|
| Model            | DL-4CD-35        | DL-4CD-35E       |
| Power            | 200W (MAX 400W)  | 200W (MAX 400W)  |
| Input voltage    | 24 V             | 15-31 V          |
| Battery Capacity | 24V 12Ah (288WH) | 24V 12Ah (288WH) |
| Battery Quantity | 1 pcs            | 1 pcs            |
| Motor Speed      | 6300 rpm         | 10500 rpm        |
| Blade Speed      | 1800 rpm         | 2450 rpm         |
| Cutting Width    | 35 cm            | 30 cm            |
| Gear ratio       | 3.5:1            | 4.3:1            |
| Machine weight   | 1.6 kgs          | 1.1 kgs          |
| Battery weight   | 2.8 kgs          | 2.8 kgs          |
| Packaging Size   | 570×190×170 mm   | 520×230×160 mm   |
| Packaging weight | 6.4 kgs          | 6 kgs            |
| Price            |                  |                  |



## Battery Tea Leaf Harvester (Portable Cordless Battery)

|                  |                  |                  |
|------------------|------------------|------------------|
| Model            | DL-4CD-35G       | DL-4CD-35E       |
| Power            | 200W (MAX 400W)  | 200W (MAX 400W)  |
| Input voltage    | 15-31 V          | 15-31 V          |
| Battery Capacity | 18V 5.2Ah (94WH) | 18V 5.2Ah (94WH) |
| Battery Quantity | 2 PCS            | 2 PCS            |
| Motor Speed      | 10500 rpm        | 10500 rpm        |
| Blade Speed      | 2450 rpm         | 2450 rpm         |
| Cutting Width    | 30 cm            | 30 cm            |
| Gear ratio       | 4.3:1            | 4.3:1            |
| Machine weight   | 1.1 kgs          | 1.1 kgs          |
| Battery weight   | 0.6 kgs          | 0.6 kgs          |
| Packaging Size   | 520×230×160 mm   | 520×230×160 mm   |
| Packaging weight | 4.5 kgs          | 4.5 kgs          |
| Price            |                  |                  |



## Blower Type Tea Leaf Harvester (Backpack Battery)

|                |                |
|----------------|----------------|
| Model          | DL-4CD-60      |
| Power          | 600W           |
| Motor Voltage  | 36             |
| Battery        | 36V 20AH       |
| Motor Speed    | 6400 rpm       |
| Blade Speed    | 1600 rpm       |
| Gear ratio     | 4:1            |
| Battery weight | 5.3 kgs        |
| Machine weight | 4.2 kgs        |
| Total weight   | 11 kgs         |
| Packing Size   | 980×310×250 mm |
| Price          |                |



## Pertrol Engine Tea Leaf Harvester (Handheld Engine)

|               |                    |                 |
|---------------|--------------------|-----------------|
| Model         | DL-4C-T50A5        | DL-4C-T606      |
| Engine Model  | NATIKA 1E34F       | MITSUBISHI TU26 |
| Stroke        | 2 Stroke           | 2 Stroke        |
| Displacement  | 25.4 CC            | 25.4 CC         |
| Power         | 0.7 KW             | 0.7 KW          |
| HP            | 0.9 HP             | 0.9 HP          |
| Packing Size  | 108×33×32cm 9.8kgs |                 |
| Cutting Width | 45cm / 60cm        |                 |
| Price         |                    |                 |



## Pertrol Engine Tea Leaf Harvester (Backpack Engine)

|                     |              |               |                    |               |            |
|---------------------|--------------|---------------|--------------------|---------------|------------|
| Model               | DL-4C-A      | DL-4C-Z       | DL-4C-T            | DL-4C-S39     | DL-4C-H3   |
| Engine Model        | NATIKA 1E34F | KOMATSU G26LS | MITSUBISHI TU26    | HUASHENG 139F | HONDA GX35 |
| Stroke              | 2 Stroke     | 2 Stroke      | 2 Stroke           | 4 Stroke      | 4 Stroke   |
| Displacement        | 25.4 CC      | 25.4 CC       | 25.4 CC            | 31 CC         | 35 CC      |
| Power               | 0.7 KW       | 0.81 KW       | 0.7 KW             | 0.7 KW        | 1.35 KW    |
| HP                  | 0.9 HP       | 1.1 HP        | 0.9 HP             | 0.9 HP        | 0.9 HP     |
| Rack Packing Size   |              |               | 98×30×25cm         | 7.8kg         |            |
| Engine Packing Size |              |               | 35×45×37cm         | 6.1kg         |            |
| Cutting Width       |              |               | 45cm / 50cm / 60cm |               |            |
| Price               |              |               |                    |               |            |



## Two Men Use Tea Leaf Harvester

| Model                      | DL-4CP Series                | DL-4CH Series |
|----------------------------|------------------------------|---------------|
| Engine Model               | G4K                          |               |
| Stroke                     | 2 Stroke                     |               |
| Displacement               | 41.5 CC                      |               |
| Power                      | 2.2 KW                       |               |
| HP                         | 2.9 HP                       |               |
| Packing Size               | 142×52×45cm 24kgs            |               |
| Blade Type                 | Straight Blade               |               |
| Cutting Width              | 1000 / 1140 / 1210 / 1600 mm |               |
| 1000mm Cutting Width Price | DL-4CP-1000                  | DL-4CH-1000   |
| 1140mm Cutting Width Price | DL-4CP-1140                  | DL-4CH-1140   |
| 121mm Cutting Width Price  | DL-4CP-1210                  | DL-4CH-1210   |
| 1600mm Cutting Width Price | DL-4CP-1600                  | /             |
|                            |                              | /             |

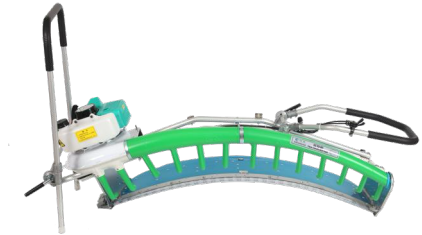

## Harvester With Wheels (For Vegetable / Lavender, etc)

| Model                      | DL-4CP-W Series              | DL-4CH-W Series |
|----------------------------|------------------------------|-----------------|
| Engine Model               | G4K                          |                 |
| Stroke                     | 2 Stroke                     |                 |
| Displacement               | 41.5 CC                      |                 |
| Power                      | 2.2 KW                       |                 |
| HP                         | 2.9 HP                       |                 |
| Packing Size               | 164×70×57cm 80kgs            |                 |
| Blade Type                 | Straight Blade               |                 |
| Cutting Width              | 1000 / 1140 / 1210 / 1600 mm |                 |
| Cutting Height             | 1-50 cm                      |                 |
| 1000mm Cutting Width Price | DL-4CP-1000W                 | DL-4CH-1000W    |
| 1140mm Cutting Width Price | DL-4CP-1140W                 | DL-4CH-1140W    |
| 121mm Cutting Width Price  | DL-4CP-1210W                 | DL-4CH-1210W    |
| 1600mm Cutting Width Price | DL-4CP-1600W                 | /               |
|                            |                              | /               |



## Multi-Function Ride On Type Tea Harvester

| Model                    | DL-4CZ-1800                            |
|--------------------------|--|
| Dimension                | 3100×2000×2360mm                       |
| Track spacing            | 1800mm                                 |
| Cutting width            | 1600mm                                 |
| Working height           | 380mm-690mm                            |
| Spray width              | 6000mm                                 |
| Safety slope angle       | ≤25°                                   |
| Low speed walking speed  | 4-5km/h                                |
| High speed walking speed | 9-11km/h                               |
| Hourly homework area     | 3300m <sup>2</sup> -4700m <sup>2</sup> |
| Rated output power       | 45KW                                   |
| Price                    |  |



## Pertrol Engine Tea Tree Hedge Trimmer (Handheld Engine Type)

| Model         | DL-3CX-750A         | DL-3CX-750H    | DL-3CX-750Z   | DL-3CX-750K    |
|---------------|---------------------|----------------|---------------|----------------|
| Engine Model  | NATIKA 1E34F        | HUASHENG 1E32F | KOMATSU G26LS | KAWASAKI TJ23V |
| Stroke        | 2 Stroke            | 2 Stroke       | 2 Stroke      | 2 Stroke       |
| Displacement  | 25.4 CC             | 25.4 CC        | 25.4 CC       | 25.4 CC        |
| Power         | 0.7 KW              | 0.7 KW         | 0.81 KW       | 0.65 KW        |
| HP            | 0.9 HP              | 0.9 HP         | 1.1 HP        | 1.2 HP         |
| Packing Size  | 111×30×29cm, 7.5kgs |                |               |                |
| Cutting Width | 750 mm              |                |               |                |
| Price         |                     |                |               |                |



## Battery Type Tea Tree Hedge Trimmer

| Model            | DL-3CX-720D     | DL-3CX-600D     | DL-3CX-35D       | DL-3CX-35D       |
|------------------|-----------------|-----------------|------------------|------------------|
| Input Voltage    | 36-48V          | 36-48V          | 24V              | 15-31 V          |
| Motor Power      | 800 W           | 800 W           | 200W (MAX 400W)  | 200W (MAX 400W)  |
| Battery Capacity | 36V 20Ah        | 36V 20Ah        | 24V 12Ah (288WH) | 24V 12Ah (288WH) |
| Battery Quantity | 1 pcs           | 1 pcs           | 1 pcs            | 1 pcs            |
| Motor Speed      | 13000 rpm       | 13000 rpm       | 6300 rpm         | 10500 rpm        |
| Blade Speed      | 2400 rpm        | 2400 rpm        | 1800 rpm         | 2450 rpm         |
| Cutting Width    | 78 cm           | 60 cm           | 35 cm            | 30 cm            |
| Gear ratio       | 5.4:1           | 5.4:1           | 3.5:1            | 4.3:1            |
| Machine weight   | 3.9 kgs         | 3.8 kgs         | 1.6 kgs          | 1.1 kgs          |
| Battery weight   | 3.6 kgs         | 3.6 kgs         | 2.8 kgs          | 2.8 kgs          |
| Packaging Size   | 1130×230×200 mm | 1130×230×200 mm | 570×190×170 mm   | 520×230×160 mm   |
| Packaging weight | 10 kgs          | 10 kgs          | 6.4 kgs          | 6 kgs            |
| Price            |                 |                 |                  |                  |



## Two Men Use Tea Tree Trimmer Machine

| Model         | DL-3CXP-1140      | DL-3CXH-1140 |
|---------------|-------------------|--------------|
| Engine Model  | MITSUBISHI TU33   |              |
| Stroke        | 2 Stroke          |              |
| Displacement  | 32.6 CC           |              |
| Power         | 1.3 KW            |              |
| HP            | 1.75 HP           |              |
| Packing Size  | 142×52×45cm 22kgs |              |
| Cutting Width | 1140mm            |              |
| Blade Type    | Straight          | Curved       |
| Price         |                   |              |



## Pertrol Engine Tea Tree Hedge Trimmer With Wheel (Tyre Type)

| Model         | DL-3CX-750A-W       | DL-3CX-750H-W  | DL-3CX-750Z-W | DL-3CX-750K-W  |
|---------------|---------------------|----------------|---------------|----------------|
| Engine Model  | NATIKA 1E34F        | HUASHENG 1E32F | KOMATSU G26LS | KAWASAKI TJ23V |
| Stroke        | 2 Stroke            | 2 Stroke       | 2 Stroke      | 2 Stroke       |
| Displacement  | 25.4 CC             | 25.4 CC        | 25.4 CC       | 25.4 CC        |
| Power         | 0.7 KW              | 0.7 KW         | 0.81 KW       | 0.65 KW        |
| HP            | 0.9 HP              | 0.9 HP         | 1.1 HP        | 1.2 HP         |
| Packing Size  | 111×30×29cm, 7.5kgs |                |               |                |
| Cutting Width | 750 mm              |                |               |                |
| Price         |                     |                |               |                |

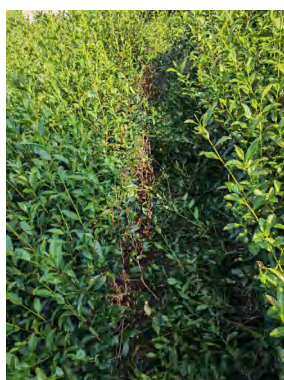

## Tea Tree Pruner Machine (90° Gear Case Head)

| Model                 | DL-TPC-430      | DL-TPC-430-S     |
|-----------------------|-----------------|------------------|
| Engine Model          | MITSUBISHI TU43 | HUASHENG 1E40F-5 |
| Stroke                | 2 Stroke        | 2 Stroke         |
| Displacement          | 42.7 CC         | 42.7 CC          |
| Power                 | 1.27            | 1.25             |
| HP                    | 1.7             | 1.7              |
| Rod length            | 1340 mm         | 1340 mm          |
| Rod diameter          | 28 mm           | 28 mm            |
| Blade teeth quantity  | 80/100 teeth    | 80/100 teeth     |
| Gear case angle       | 90°Right Angle  | 90°Right Angle   |
| Engine Package Size   | 340×260×370 mm  | 340×260×370 mm   |
| Engine Package Weight | 6.9 kgs         | 6.9 kgs          |
| Rod Package Size      | 1490×135×140 mm | 1490×135×140 mm  |
| Rod Package Weight    | 4.1 kgs         | 4.1 kgs          |
| Price                 |                 |                  |



# 茶叶做青系列

## TEA WITHERING EQUIPMENTS

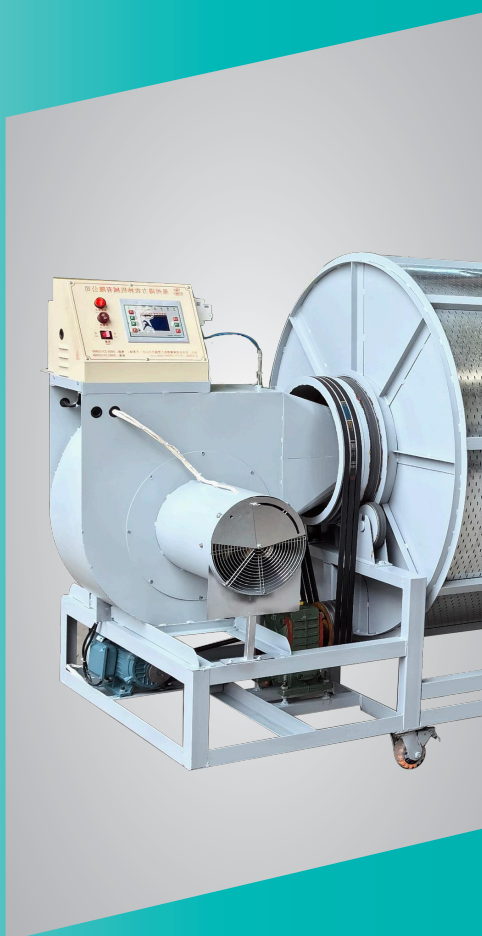

## Tea Withering Rack

| Model           | DL-TQJ-20               | DL-TQJ-20QB     |
|-----------------|-------------------------|-----------------|
| Expanded size   |                         |                 |
| Sieve Diameter  | ≈ 108-110 cm            | ≈ 108-110 cm    |
| Sieve Height    | ≈ 3 cm                  | ≈ 3 cm          |
| Layers          | 20                      | 20              |
| Layer Distance  | 12 cm                   | 12 cm           |
| Sieve Materials | Bamboo                  | Stainless Steel |
| Rack Materials  | Galvanized steel        | Stainless Steel |
| Capacity        | 2.5kg/sieve , 50kg/rack |                 |
| Price           |                         |                 |



## Tea Withering Head (Without Trough)

| Model                   | DL-6CWD-80       | DL-6CWD-90        |
|-------------------------|------------------|-------------------|
| Dimension               | 1100×900×930 mm  | 1300×1100×1100 mm |
| Voltage                 | 380V 50Hz        | 380V 50Hz         |
| Heating Type            | Heating Wire     | Heating Wire      |
| Heating Power           | 18 kW            | 24 kW             |
| Heating Element Group   | 6 kW × 3         | 4 kW × 6          |
| Fan Motor               | 0.25 KW          | 0.37 KW           |
| Fan Speed               | 850 RPM          | 850 RPM           |
| Fan Voltage             | 220V             | 220V              |
| Rated Air Volume / Hour | 20000 m³/h       | 27000 m³/h        |
| Suitable Trough Length  | 2.5 - 5.0 meters | 7.5 - 10 meters   |
| Price                   |                  |                   |



## Tea Withering Trough Machine (Complete Machine)

| Model                            | DL-6CWD-803      | DL-6CWD-805      | DL-6CWD-807      | DL-6CWD-907      | DL-6CWD-9010      |
|----------------------------------|------------------|------------------|------------------|------------------|-------------------|
| Dimension                        | 3300×1100×950 mm | 5800×1100×950 mm | 8300×1100×950 mm | 8300×1200×950 mm | 10800×1200×950 mm |
| Voltage                          | 380V 50Hz        | 380V 50Hz        | 380V 50Hz        | 380V 50Hz        | 380V 50Hz         |
| Heating Type                     | Heating Wire     | Heating Wire     | Heating Wire     | Heating Wire     | Heating Wire      |
| Total Power                      | 18.25 KW         | 18.25 KW         | 18.25 KW         | 24.37 KW         | 24.37 KW          |
| Withering Head Model             | DL-6CWD-80       | DL-6CWD-80       | DL-6CWD-80       | DL-6CWD-90       | DL-6CWD-90        |
| Rated Air Volume / Hour          | 20000 m³/h       | 20000 m³/h       | 20000 m³/h       | 27000 m³/h       | 27000 m³/h        |
| Effective Trough Size            | 2500×1000×200 mm | 5000×1000×200 mm | 7500×1000×200 mm | 7500×1100×200 mm | 7500×1100×200 mm  |
| Capacity                         | 50 kg/batch      | 100 kg/batch     | 150 kg/batch     | 165 kg/batch     | 220 kg/batch      |
| Price (Color Steel Board Trough) |                  |                  |                  |                  |                   |
| Price (Stainless Steel Trough)   |                  |                  |                  |                  |                   |



Standard Control Box



Optional Speed Controller

## Oolong Tea Hot Air Shaking Machine (Steel Drum)

| Model                         | DL-6CZQ-D110-3         | DL-6CZQ-D110-4   | DL-6CZQ-120-3    |
|-------------------------------|------------------------|------------------|------------------|
| Dimension                     | 4000x1130x1500mm       | 5000x1130x1500mm | 4000x1230x1580mm |
| Voltage                       | 380V 50Hz              | 380V 50Hz        | 380V 50Hz        |
| Heating Power                 | 18 KW                  | 18 KW            | 18 KW            |
| Drum Driven Motor             | Power                  | 2.2 kW           | 2.2 kW           |
|                               | Speed                  | 1400 r/min       | 1400 r/min       |
|                               | Voltage                | 380 V            | 380 V            |
| Blower Fan Motor              | Power                  | 1.5 kW           | 2.2 kW           |
|                               | Speed                  | 1400 r/min       | 1400 r/min       |
|                               | Voltage                | 380 V            | 380 V            |
| Drum Rotate Speed             | 15-30 r/min            | 15-30 r/min      | 15-30 r/min      |
| Drum Diameter                 | 1100 mm                | 1100 mm          | 1200 mm          |
| Drum Length                   | 3000 mm                | 4000 mm          | 3000 mm          |
| Capacity                      | 150 kg/batch           | 200 kg/batch     | 180 kg/batch     |
| Price                         |                        |                  |                  |
| Application                   | Oolong Tea / Black Tea |                  |                  |
| Price (Galvanized Steel Drum) |                        |                  |                  |
| Price (Stainless Steel Drum)  |                        |                  |                  |



## Oolong Tea Shaking Machine (Bamboo Drum)

| Model          | DL-6CYQT-60150   | DL-6CYQT-90250   | DL-6CYQT-90300   | DL-6CYQT-90400   |
|----------------|------------------|------------------|------------------|------------------|
| Dimension      | 2100×800×1000 mm | 3200×900×1150 mm | 3700×900×1150 mm | 4700×900×1150 mm |
| Voltage        | 220V / 380V      | 220V / 380V      | 220V / 380V      | 220V / 380V      |
| Drum Diameter  | 600 mm           | 900 mm           | 900 mm           | 900 mm           |
| Drum Length    | 1500 mm          | 2500 mm          | 3000 mm          | 4000 mm          |
| Motor Power    | 0.75 kW          | 1.1 kw           | 1.1 kw           | 1.1 kw           |
| Motor Speed    | 1400 r/min       | 1400 r/min       | 1400 r/min       | 1400 r/min       |
| Motor Voltage  | 380 V            | 380 V            | 380 V            | 380 V            |
| Drum Speed     | 0-30 r/min       | 0-30 r/min       | 0-30 r/min       | 0-30 r/min       |
| Drum Materials | Bamboo           |                  |                  |                  |
| Capacity       | 32 kg/time       | 120 kg/time      | 144 kg/time      | 192 kg/time      |
| Price          |                  |                  |                  |                  |



## Fresh Leaf Cutting Machine (Cut To Small Size)

| Model         | DL-6GCQ-30      | DL-6GCQ-50      |
|---------------|-----------------|-----------------|
| Dimension     | 600×1300×900 mm | 760×1350×900 mm |
| Voltage       | 220/380V 50Hz   | 220/380V 50Hz   |
| Power         | 1.1 KW          | 1.1 KW          |
| Motor Speed   | 1400 rpm        | 1400 rpm        |
| Motor Voltage | 220/380V        | 220/380V        |
| Belt Width    | 300 mm          | 500 mm          |
| Cutting Width | 290 mm          | 490 mm          |
| Capacity      | 150 kg/h        | 250 kg/h        |
| Price         |                 |                 |



## Fresh Leaf Winnowing Sorting Machine (For Hand Plucked Leaf)

|                           |                  |                 |
|---------------------------|------------------|-----------------|
| Model                     | DL-6CFX-F30-3    | DL-6CFX-F30-3QB |
| Materials                 | Galvanized Steel | Stainless Steel |
| Dimension                 | 1200x1200x1420mm |                 |
| Voltage                   | 220V 50Hz        |                 |
| Power                     | 0.75 kW          |                 |
| Feed Type                 | Vibration Feeder |                 |
| Blower Type               | Bottom Blow      |                 |
| Outlet Quantity           | 4 pcs            |                 |
| Blower Speed Control Type | VFD              |                 |
| Machine Weight            | 62 kgs           |                 |
| Capacity                  | 100 kg/h         |                 |
| Price                     |                  |                 |



## Fresh Leaf Color Sorting Machine (For All Kind Tea)

|                             |                   |
|-----------------------------|-------------------|
| Model                       | DL-6CSX-T1L6      |
| Dimension                   | 2670×2990×1400 mm |
| Voltage                     | 380V 50Hz         |
| Layers                      | 1 Layer           |
| Machine Power               | 4.8 kW            |
| Air Compressor Power        | 7.5 kW            |
| Air Pressure                | 0.6-0.8 Mpa       |
| Accuracy                    | ≥99%              |
| Carryover Rate (Bad : Good) | > 40:1            |
| Output                      | ≤ 700 kg/h        |
| Price                       |                   |



## CTC Tea Rotorvane Machine

|               |                 |                  |
|---------------|-----------------|------------------|
| Model         | DL-6CRQ-20Z     | DL-6CRQ-450      |
| Dimension     | 2560×660×830 mm | 4200×980×1800 mm |
| Voltage       | 380V 50Hz       | 380V 50Hz        |
| Power         | 5.5 kW          | 7.5 kW           |
| Drum Diameter | 200 mm          | 450 mm           |
| Drum Length   | 915 mm          | 1300 mm          |
| Rod Speed     | 34 r/min        | 34 r/min         |
| Power         | 5.5 kW          | 7.5 kW           |
| Weight        | 600 KG          | 900 KG           |
| Capacity      | 1000 kg/h       | 3000 kg/h        |
| Price         |                 |                  |



## Soft Mat Basket For Tea Processing

|             |                                       |              |
|-------------|---------------------------------------|--------------|
| Model       | DL-6CRH-120B                          | DL-6CRH-120Z |
| Diameter    | 120cm                                 | 120cm        |
| Materials   | Inside Bamboo<br>Outside Cotton Cloth | All Bamboo   |
| Flexibility | 90%                                   | 90%          |
| Weight      | 1.5 kgs                               | 1.5 kgs      |
| Price       |                                       |              |



# 茶叶杀青设备系列

## TEA FIXATION EQUIPMENTS



## Gas Heating Tea Fixation Machine

| Model                   | DL-6CST-50          | DL-6CST-50B         | DL-6CST-50QB    |
|-------------------------|---------------------|---------------------|-----------------|
| Inner Drum Materials    | Carbon Steel        | Stainless Steel     | Stainless Steel |
| Outside Materials       | Painted Steel Board | Painted Steel Board | Stainless Steel |
| Dimension               | 850×1150×1250 mm    |                     |                 |
| Voltage                 | 220V 50Hz           |                     |                 |
| Drum Diameter           | 500 mm              |                     |                 |
| Drum Length             | 600 mm              |                     |                 |
| Drive Motor Power       | 0.75 KW             |                     |                 |
| Exhaust Fan Motor Power | 85 W                |                     |                 |
| Drum Speed              | 5-37 min            |                     |                 |
| Heating Fuel            | Gas                 |                     |                 |
| Gas Consumption         |                     |                     |                 |
| Capacity Per Hour       | 25 kg/hour          |                     |                 |
| Price                   |                     |                     |                 |



| Model                   | DL-6CST-70          | DL-6CST-70B         | DL-6CST-70QB    |
|-------------------------|---------------------|---------------------|-----------------|
| Inner Drum Materials    | Carbon Steel        | Stainless Steel     | Stainless Steel |
| Outside Materials       | Painted Steel Board | Painted Steel Board | Stainless Steel |
| Dimension               | 1100×1750×1680 mm   |                     |                 |
| Voltage                 | 220V 50Hz           |                     |                 |
| Drum Diameter           | 700 mm              |                     |                 |
| Drum Length             | 1000 mm             |                     |                 |
| Drive Motor Power       | 0.75 KW             |                     |                 |
| Exhaust Fan Motor Power | 85 W                |                     |                 |
| Drum Speed              | 5-37 rpm            |                     |                 |
| Heating Fuel            | Gas                 |                     |                 |
| Gas Consumption         |                     |                     |                 |
| Capacity Per Hour       | 50 kg/hour          |                     |                 |
| Price                   |                     |                     |                 |



| Model                   | DL-6CST-90          | DL-6CST-90B         | DL-6CST-90QB    |
|-------------------------|---------------------|---------------------|-----------------|
| Inner Drum Materials    | Carbon Steel        | Stainless Steel     | Stainless Steel |
| Outside Materials       | Painted Steel Board | Painted Steel Board | Stainless Steel |
| Dimension               | 1250×2250×1900 mm   |                     |                 |
| Voltage                 | 220V/380V 50Hz      |                     |                 |
| Drum Diameter           | 900 mm              |                     |                 |
| Drum Length             | 1240 mm             |                     |                 |
| Drive Motor Power       | 0.75 KW             |                     |                 |
| Exhaust Fan Motor Power | 85 W                |                     |                 |
| Drum Speed              | 5-37 rpm            |                     |                 |
| Heating Fuel            | Gas                 |                     |                 |
| Gas Consumption         |                     |                     |                 |
| Capacity Per Hour       | 100 kg/hour         |                     |                 |
| Price                   |                     |                     |                 |



| Model                   | DL-6CST-100         | DL-6CST-100B        | DL-6CST-100QB   |
|-------------------------|---------------------|---------------------|-----------------|
| Inner Drum Materials    | Carbon Steel        | Stainless Steel     | Stainless Steel |
| Outside Materials       | Painted Steel Board | Painted Steel Board | Stainless Steel |
| Dimension               | 1400×2300×2100 mm   |                     |                 |
| Voltage                 | 220V/380V 50Hz      |                     |                 |
| Drum Diameter           | 1000 mm             |                     |                 |
| Drum Length             | 1250 mm             |                     |                 |
| Drive Motor Power       | 0.75 KW             |                     |                 |
| Exhaust Fan Motor Power | 85 W                |                     |                 |
| Drum Speed              | 5-37 rpm            |                     |                 |
| Heating Fuel            | Gas                 |                     |                 |
| Gas Consumption         |                     |                     |                 |
| Capacity Per Hour       | 150 kg/hour         |                     |                 |
| Price                   |                     |                     |                 |



## Electric Heating Tea Fixation Machine

| Model                | DL-6CST-D50         | DL-6CST-D50B        | DL-6CST-D50QB   |
|----------------------|---------------------|---------------------|-----------------|
| Inner Drum Materials | Carbon Steel        | Stainless Steel     | Stainless Steel |
| Outside Materials    | Painted Steel Board | Painted Steel Board | Stainless Steel |
| Dimension            | 780×1400×1530 mm    |                     |                 |
| Voltage              | 380V 50Hz           |                     |                 |
| Drum Diameter        | 500 mm              |                     |                 |
| Drum Length          | 600 mm              |                     |                 |
| Heating Power        | 18 KW               |                     |                 |
| Drum Drive Motor     | Power               | 0.75 KW             |                 |
|                      | Speed               | 1390 rpm            |                 |
|                      | Voltage             | 220 V               |                 |
| Exhaust Fan Motor    | Power               | 85 W                |                 |
|                      | Speed               | 2200 rpm            |                 |
|                      | Voltage             | 220 V               |                 |
| Drum Speed           | 5-37 min            |                     |                 |
| Heating Type         | Electric            |                     |                 |
| Capacity             | 25 kg/h             |                     |                 |
| Price                |                     |                     |                 |



| Model                | DL-6CST-D70         | DL-6CST-D70B        | DL-6CST-D70QB   |
|----------------------|---------------------|---------------------|-----------------|
| Inner Drum Materials | Carbon Steel        | Stainless Steel     | Stainless Steel |
| Outside Materials    | Painted Steel Board | Painted Steel Board | Stainless Steel |
| Dimension            | 980×1565×1630 mm    |                     |                 |
| Voltage              | 380V 50Hz           |                     |                 |
| Drum Diameter        | 700 mm              |                     |                 |
| Drum Length          | 1000 mm             |                     |                 |
| Heating Power        | 24 KW               |                     |                 |
| Drum Drive Motor     | Power               | 0.75 KW             |                 |
|                      | Speed               | 1390 rpm            |                 |
|                      | Voltage             | 220 V               |                 |
| Exhaust Fan Motor    | Power               | 85 W                |                 |
|                      | Speed               | 2200 rpm            |                 |
|                      | Voltage             | 220 V               |                 |
| Drum Speed           | 5-37 min            |                     |                 |
| Heating Type         | Electric            |                     |                 |
| Capacity             | 50 kg/h             |                     |                 |
| Price                |                     |                     |                 |



**Optional Pneumatic Discharge**



**Full SS Type**



**Computer Board Control Box**

## Tea Fixation Machine & Revolving Dryer Machine (Wood/coal heating)

| Model                        | DL-6CSTP-CM110<br>(Carbon Iron Pot)       | DL-6CSTP-CM110Z<br>(Cast Iron Pot) | DL-6CSTP-CM120<br>(Carbon Iron Pot) |
|------------------------------|---|------------------------------------|-------------------------------------|
| Dimension                    | 1300×2100×2000 mm                         | 1300×2100×2000 mm                  | 1450×2150×2300 mm                   |
| Voltage                      | 220/380V 50Hz                             | 220/380V 50Hz                      | 220/380V 50Hz                       |
| Drum Diameter                | 1100 mm                                   | 1100 mm                            | 1200 mm                             |
| Drum Length                  | 1000 mm                                   | 1000 mm                            | 1000 mm                             |
| Drum Materials               | Carbon Steel                              | Poured Cast Iron                   | Carbon Steel                        |
| Drum Thickness               | 4 mm / 8 mm                               | ≈ 10 mm                            | 4 mm / 8 mm                         |
| Drive Motor Power            | 1.5 kw                                    | 1.5 kw                             | 1.5 kw                              |
| Exhaust Fan Power            | 0.18 kw                                   | 0.18 kw                            | 0.18 kw                             |
| Blower Fan Power             | 0.15 kw                                   | 0.15 kw                            | 0.15 kw                             |
| Rotate Speed                 | 5-37 rpm                                  | 5-37 rpm                           | 5-37 rpm                            |
| Heating Type                 | Wood / Coal / Wood Pellets / Biomass Fuel |                                    |                                     |
| Capacity                     | 35 kg/batch                               | 35 kg/batch                        | 45 kg/batch                         |
| Price (Normal Steel Drum)    |   |                                    |                                     |
| Price (Stainless Steel Drum) |   |                                    |                                     |



## Tea Fixation Machine & Revolving Dryer Machine (Electric heating)

| Model                        | DL-6CSTP-D110             |
|------------------------------|---------------------------|
| Dimension                    | 2100×1350×1880 mm         |
| Voltage                      | 380V 50Hz                 |
| Drum Diameter                | 1100 mm                   |
| Drum Length                  | 1000 mm                   |
| Drum Materials               | Welded Carbon Steel Board |
| Drum Thickness               | 4 mm                      |
| Drive Motor Power            | 1.5 kw                    |
| Exhaust Fan Power            | 0.18 kw                   |
| Rotate Speed                 | 5-37 rpm                  |
| Heating Type                 | Electric                  |
| Heating Power                | 36 KW                     |
| Capacity                     | 35 kg/batch               |
| Price (Normal Steel Drum)    |                           |
| Price (Stainless Steel Drum) |                           |



## Tea Fixation Machine & Revolving Dryer Machine (Gas heating)

| Model                        | DL-6CSTP-Q110<br>(Carbon Iron Pot) | DL-6CSTP-Q110Z<br>(Cast Iron Pot) |
|------------------------------|------------------------------------|-----------------------------------|
| Dimension                    | 2100×1350×1880 mm                  | 2100×1350×1880 mm                 |
| Voltage                      | 220/380V 50Hz                      | 220/380V 50Hz                     |
| Drum Diameter                | 1100 mm                            | 1100 mm                           |
| Drum Length                  | 1000 mm                            | 1000 mm                           |
| Drum Materials               | Welded Carbon Steel                | Poured Cast Iron                  |
| Drum Thickness               | 4 mm                               | ≈ 10 mm                           |
| Drive Motor Power            | 1.5 kw                             | 1.5 kw                            |
| Exhaust Fan Power            | 0.18 kw                            | 0.18 kw                           |
| Heating Type                 | Gas                                | Gas                               |
| Rotate Speed                 | 5-37 rpm                           | 5-37 rpm                          |
| Capacity                     | 35 kg/batch                        |                                   |
| Price (Normal Steel Drum)    |                                    |                                   |
| Price (Stainless Steel Drum) |                                    |                                   |



## Continuous Type Tea Fixation Machine (De-Enzymer Machine)

| Model                        | DL-6CSTL-CM40                             | DL-6CSTL-CM50    | DL-6CSTL-CM60     | DL-6CSTL-CM80     | DL-6CSTL-CM100    | DL-6CSTL-CM110    | DL-6CSTL-CM120    |
|------------------------------|---|------------------|-------------------|-------------------|-------------------|-------------------|-------------------|
| Dimension                    | 2300×700×1250 mm                          | 3000×850×1250 mm | 3600×1100×1650 mm | 4700×1250×1900 mm | 5700×1550×2100 mm | 6700×1750×2300 mm | 8800×1900×2400 mm |
| Voltage                      | 220V 50Hz                                 | 220V 50Hz        | 220V/380V 50Hz    | 220V/380V 50Hz    | 380V 50Hz         | 380V 50Hz         | 380V 50Hz         |
| Drum Diameter                | 40 cm                                     | 50 cm            | 60 cm             | 80 cm             | 100 cm            | 110 cm            | 120 cm            |
| Drum Length                  | 1800 mm                                   | 2600 mm          | 3000 mm           | 4000 mm           | 5000 mm           | 6000 mm           | 7000 mm           |
| Motor Power                  | 0.75 kw                                   | 0.75 kw          | 1.1 kw            | 1.1 kw            | 3.5 kw            | 3.5 kw            | 3.5 kw            |
| Speed                        | 1400 rpm                                  | 1400 rpm         | 1400 rpm          | 1400 rpm          | 1400 rpm          | 1400 rpm          | 1400 rpm          |
| Voltage                      | 220 V                                     | 220 V            | 220/380 V         | 220/380 V         | 380 V             | 380 V             | 380 V             |
| Rotate Speed                 | 5-37 rpm                                  | 5-37 rpm         | 5-37 rpm          | 5-37 rpm          | 5-37 rpm          | 5-37 rpm          | 5-37 rpm          |
| Heating Type                 | Wood / Coal / Wood Pellets / Biomass Fuel |                  |                   |                   |                   |                   |                   |
| Capacity                     | 25 kg/h                                   | 50 kg/h          | 80 kg/h           | 150 kg/h          | 400 kg/h          | 500 kg/h          | 700 kg/h          |
| Price (Carbon Steel Drum)    |   |                  |                   |                   |                   |                   |                   |
| Price (Stainless Steel Drum) |   |                  |                   |                   |                   |                   |                   |

| Model                        | DL-6CSTL-Q40                         | DL-6CSTL-Q50     | DL-6CSTL-Q60      | DL-6CSTL-Q80      | DL-6CSTL-Q100     | DL-6CSTL-Q110     | DL-6CSTL-Q120     |
|------------------------------|--------------------------------------|------------------|-------------------|-------------------|-------------------|-------------------|-------------------|
| Dimension                    | 2300×700×1250 mm                     | 3000×850×1250 mm | 3600×1100×1650 mm | 4700×1250×1900 mm | 5700×1550×2100 mm | 6700×1750×2300 mm | 8800×1900×2400 mm |
| Voltage                      | 220V 50Hz                            | 220V 50Hz        | 220V/380V 50Hz    | 220V/380V 50Hz    | 380V 50Hz         | 380V 50Hz         | 380V 50Hz         |
| Drum Diameter                | 40 cm                                | 50 cm            | 60 cm             | 80 cm             | 100 cm            | 110 cm            | 120 cm            |
| Drum Length                  | 1800 mm                              | 2600 mm          | 3000 mm           | 4000 mm           | 5000 mm           | 6000 mm           | 7000 mm           |
| Motor Power                  | 0.75 kw                              | 0.75 kw          | 1.1 kw            | 1.1 kw            | 3.5 kw            | 3.5 kw            | 3.5 kw            |
| Speed                        | 1400 rpm                             | 1400 rpm         | 1400 rpm          | 1400 rpm          | 1400 rpm          | 1400 rpm          | 1400 rpm          |
| Voltage                      | 220 V                                | 220 V            | 220/380 V         | 220/380 V         | 380 V             | 380 V             | 380 V             |
| Rotate Speed                 | 5-37 rpm                             | 5-37 rpm         | 5-37 rpm          | 5-37 rpm          | 5-37 rpm          | 5-37 rpm          | 5-37 rpm          |
| Heating Type                 | Natural Gas / Liquid Gas / LPG / LNG |                  |                   |                   |                   |                   |                   |
| Capacity                     | 25 kg/h                              | 50 kg/h          | 80 kg/h           | 150 kg/h          | 400 kg/h          | 500 kg/h          | 700 kg/h          |
| Price (Carbon Steel Drum)    |                                      |                  |                   |                   |                   |                   |                   |
| Price (Stainless Steel Drum) |                                      |                  |                   |                   |                   |                   |                   |

| Model                        | DL-6CSTL-D40     | DL-6CSTL-D50     | DL-6CSTL-D60      | DL-6CSTL-D80      | DL-6CSTL-D100     | DL-6CSTL-D110     | DL-6CSTL-D120     |
|------------------------------|------------------|------------------|-------------------|-------------------|-------------------|-------------------|-------------------|
| Dimension                    | 2300×700×1250 mm | 3000×850×1250 mm | 3600×1100×1650 mm | 4700×1250×1900 mm | 5700×1550×2100 mm | 6700×1750×2300 mm | 8800×1900×2400 mm |
| Voltage                      | 380V 50Hz        | 380V 50Hz        | 380V 50Hz         | 380V 50Hz         | 380V 50Hz         | 380V 50Hz         | 380V 50Hz         |
| Drum Diameter                | 40 cm            | 50 cm            | 60 cm             | 80 cm             | 100 cm            | 110 cm            | 120 cm            |
| Drum Length                  | 1800 mm          | 2600 mm          | 3000 mm           | 4000 mm           | 5000 mm           | 6000 mm           | 7000 mm           |
| Motor Power                  | 0.75 kw          | 0.75 kw          | 1.1 kw            | 1.1 kw            | 3.5 kw            | 3.5 kw            | 3.5 kw            |
| Speed                        | 1400 rpm         | 1400 rpm         | 1400 rpm          | 1400 rpm          | 1400 rpm          | 1400 rpm          | 1400 rpm          |
| Voltage                      | 220 V            | 220 V            | 220/380 V         | 220/380 V         | 380 V             | 380 V             | 380 V             |
| Rotate Speed                 | 5-37 rpm         | 5-37 rpm         | 5-37 rpm          | 5-37 rpm          | 5-37 rpm          | 5-37 rpm          | 5-37 rpm          |
| Heating Type                 | Electric         |                  |                   |                   |                   |                   |                   |
| Heating Power                | 21 KW            | 35 KW            | 60 KW             | 108 KW            | 126 KW            | 162 KW            | 186 KW            |
| Capacity                     | 25 kg/h          | 50 kg/h          | 80 kg/h           | 150 kg/h          | 400 kg/h          | 500 kg/h          | 700 kg/h          |
| Price (Carbon Steel Drum)    |                  |                  |                   |                   |                   |                   |                   |
| Price (Stainless Steel Drum) |                  |                  |                   |                   |                   |                   |                   |



Wood/Coal Heating



Gas Heating



Electric Heating

## High-End Tea Fixation Pot (Imitation of Handmade Tea)

### · Gas Heating

|                  |                    |                   |
|------------------|--------------------|-------------------|
| Model            | DL-6CSTG-100       | DL-6CSTG-100YZ    |
| Dimension        | 1400×1600×1800 mm  | 1400×1600×1800 mm |
| Voltage          | 220V/380V 50Hz     | 220V/380V 50Hz    |
| Pot Materials    | Welded Carbon Iron | Poured Cast Iron  |
| Pot Thickness    | 6 mm               | 10-12 mm          |
| Pot Diameter     | 1000 mm            | 1000 mm           |
| Pot Depth        | 950 mm             | 1060 mm           |
| Motor Power      | 0.5 KW             | 0.5 KW            |
| Blower Fan Power | 60 W               | 60 W              |
| Pot Speed        | 5-37 rpm           | 5-37 rpm          |
| Heating Type     | Gas                | Gas               |
| Discharge Type   | Manual             |                   |
| Capacity         | 20 kg/batch        | 20 kg/batch       |
| Price            |                    |                   |



### · Electric Heating

|                       |                          |
|-----------------------|--------------------------|
| Model                 | DL-6CSTG-DC100QZ-UZ      |
| Dimension             | 1390×1670×1660 mm        |
| Voltage               | 380V 50Hz                |
| Pot Materials         | Poured Cast Iron         |
| Pot Thickness         | 10-12 mm                 |
| Pot Diameter          | 1000 mm                  |
| Pot Depth             | 1040 mm                  |
| Motor Power           | 0.5 KW                   |
| Blower Fan Power      | 60 W                     |
| Discharge Motor Power | 250 W                    |
| Pot Speed             | 5-37 rpm                 |
| Heating Type          | High-Frequency Induction |
| Discharge Type        | Automatic Discharge      |
| Capacity              | 20 kg/batch              |
| Price                 |                          |



### · Gas Heating / Wood Coal Heating

|                       |                     |                   |                            |                   |
|-----------------------|---------------------|-------------------|----------------------------|-------------------|
| Model                 | DL-6CSTG-100QB-UZ   | DL-6CSTG-100QB-YZ | DL-6CSTG-CM100-UZ          | DL-6CSTG-CM100-YZ |
| Dimension             | 1510×1610×1740 mm   | 1650×1650×1720 mm | 1465×1835×1920 mm          | 1665×1620×1810 mm |
| Voltage               | 220V/380V 50Hz      | 220V/380V 50Hz    | 220V/380V 50Hz             | 220V/380V 50Hz    |
| Pot Materials         | Poured Cast Iron    | Poured Cast Iron  | Poured Cast Iron           | Poured Cast Iron  |
| Pot Thickness         | 10-12 mm            | 10-12 mm          | 10-12 mm                   | 10-12 mm          |
| Pot Diameter          | 1000 mm             | 1000 mm           | 1000 mm                    | 1000 mm           |
| Pot Depth             | 1040 mm             | 1060 mm           | 1040 mm                    | 1060 mm           |
| Motor Power           | 0.5 KW              | 0.5 KW            | 0.5 KW                     | 0.5 KW            |
| Blower Fan Power      | 60 W                | 60 W              | 60 W                       | 60 W              |
| Discharge Motor Power | 250 W               | 250 W             | 250 W                      | 250 W             |
| Pot Speed             | 5-37 rpm            | 5-37 rpm          | 5-37 rpm                   | 5-37 rpm          |
| Heating Type          | Gas                 |                   | Wood / Coal / Biomass Fuel |                   |
| Discharge Type        | Automatic Discharge |                   |                            |                   |
| Capacity              | 20 kg/batch         | 20 kg/batch       | 20 kg/batch                | 20 kg/batch       |
| Price                 |                     |                   |                            |                   |



## Automatic Cooling & Softing Conveyor Machine

|                    |                   |
|--------------------|-------------------|
| Model              | DL-6CNQHCL-16     |
| Dimension          | 6000×1020×2020 mm |
| Voltage            | 380V 50Hz         |
| Cooling Area       | 15 m <sup>2</sup> |
| Cooling Layers     | 3 Layer           |
| Fan Motor Power    | 0.085 KW          |
| Drive Motor Power  | 1.5 KW            |
| Feed Motor Power   | 0.75 KW           |
| Output Motor Power | 0.18 KW           |
| Price              |                   |



## Handmade Tea Fixation Pot (Hand Roasting Pot)

| Model              | DL-6CSCG-60           | DL-6CSCG-60B          |
|--------------------|-----------------------|-----------------------|
| Dimension          | 800×800×390 mm        | 770×700×780 mm        |
| Voltage            | 220V 50Hz             | 220V 50Hz             |
| Heating Type       | Electric heating wire | Electric heating wire |
| Heating Power      | 3 KW                  | 4.5 KW                |
| Pot Diameter       | 600 mm                | 570 mm                |
| Pot Depth          | 220 mm                | 220 mm                |
| Capacity           | 2 kg/batch            | 2 kg/batch            |
| Platform Materials | Wood                  | Stainless Steel       |
| Price              |                       |                       |



DL-6CSCG-60



DL-6CSCG-60B

## Corollary Equipment During Fixation Step



Cooling&Softing Platform



De-Enzymer Machine  
Feed Conveyor



De-Enzymer Machine  
Cooling Conveyor

# 茶叶揉捻机设备系列

## TEA ROLLING EQUIPMENTS



## Tea Rolling Machine

| Model                 | DL-6CRT-25     | DL-6CRT-30        |
|-----------------------|----------------|-------------------|
| Dimension             | 690×600×950 mm | 1000×1000×1060 mm |
| Voltage               | 220V 50Hz      | 220V 50Hz         |
| Rolling Disc Diameter | 485 mm         | 585 mm            |
| Drum Diameter         | 250 mm         | 300 mm            |
| Drum Height           | 180 mm         | 210 mm            |
| Drive Motor           | Power          | 0.37 kW           |
|                       | Speed          | 1400 RPM          |
|                       | Voltage        | 220 V             |
| Drum Speed            | 42 RPM         | 42 RPM            |
| Machine Weight        | 70 Kg          | 90 Kg             |
| Capacity (Per Batch)  | ≥ 3 kg         | ≥ 5 kg            |
| Price                 |                |                   |



| Model                 | DL-6CRT-35       | DL-6CRT-40       |
|-----------------------|------------------|------------------|
| Dimension             | 1100×850×1060 mm | 1160×930×1240 mm |
| Voltage               | 220V 50Hz        | 380V 50Hz        |
| Rolling Disc Diameter | 720 mm           | 795 mm           |
| Drum Diameter         | 350 mm           | 400 mm           |
| Drum Height           | 260 mm           | 250 mm           |
| Drive Motor           | Power            | 1.1 kW           |
|                       | Speed            | 1400 RPM         |
|                       | Voltage          | 220 V            |
| Drum Speed            | 42 RPM           | 42 RPM           |
| Machine Weight        | 145 Kg           | 153 Kg           |
| Capacity (Per Batch)  | ≥ 8 kg           | ≥ 11 kg          |
| Price                 |                  |                  |



| Model                 | DL-6CRT-45        | DL-6CRT-50        |
|-----------------------|-------------------|-------------------|
| Dimension             | 1250×1000×1230 mm | 1270×1100×1280 mm |
| Voltage               | 380V 50Hz         | 380V 50Hz         |
| Rolling Disc Diameter | 885 mm            | 1000 mm           |
| Drum Diameter         | 450 mm            | 500 mm            |
| Drum Height           | 280 mm            | 320 mm            |
| Drive Motor           | Power             | 1.5 kW            |
|                       | Speed             | 1400 RPM          |
|                       | Voltage           | 380 V             |
| Drum Speed            | 52 RPM            | 60 RPM            |
| Machine Weight        | 175 Kg            | 280 Kg            |
| Capacity (Per Batch)  | ≥ 15 kg           | ≥ 20 kg           |
| Price                 |                   |                   |



| Model                 | DL-6CRT-55        | DL-6CRT-65        |
|-----------------------|-------------------|-------------------|
| Dimension             | 1400×1180×1400 mm | 1550×1400×1650 mm |
| Voltage               | 380V 50Hz         | 380V 50Hz         |
| Rolling Disc Diameter | 1050 mm           | 1210 mm           |
| Drum Diameter         | 550 mm            | 650 mm            |
| Drum Height           | 400 mm            | 480 mm            |
| Drive Motor           | Power             | 2.2 kW            |
|                       | Speed             | 1400 RPM          |
|                       | Voltage           | 380 V             |
| Drum Speed            | 45 RPM            | 44 RPM            |
| Machine Weight        | 420 Kg            | 495 Kg            |
| Capacity (Per Batch)  | ≥ 35 kg           | ≥ 60 kg           |
| Price                 |                   |                   |



## Tea Rolling Machine

| Model                 | DL-6CRT-75        | DL-6CRT-85        |
|-----------------------|-------------------|-------------------|
| Dimension             | 2000x1650x2000 mm | 2000x1800x2250 mm |
| Voltage               | 380V 50Hz         | 380V 50Hz         |
| Rolling Disc Diameter | 1310 mm           | 1550 mm           |
| Drum Diameter         | 750 mm            | 850 mm            |
| Drum Height           | 580 mm            | 830 mm            |
| Drive Motor           | Power             | 4 kW              |
|                       | Speed             | 1430 RPM          |
|                       | Voltage           | 380 V             |
| Drum Speed            | 35 RPM            | 35 rpm            |
| Machine Weight        | 1075 Kg           |                   |
| Capacity (Per Batch)  | ≥ 100 kg          | ≥ 200 kg          |
| Price                 |                   |                   |



## Tea Rolling Machine (Drum & Disc Move Together)

| Model                 | DL-6CRT-90        |          |
|-----------------------|-------------------|----------|
| Dimension             | 2240x2200x3250 mm |          |
| Voltage               | 380V 50Hz         |          |
| Rolling Disc Diameter | 1540 mm           |          |
| Drum Diameter         | 900 mm            |          |
| Drum Height           | 1000 mm           |          |
| Drive Motor           | Power             | 5.5 kw   |
|                       | Speed             | 1400 rpm |
|                       | Voltage           | 380 V    |
| Drum Speed            | 25-35 RPM         |          |
| Disc Speed            | 25-35 RPM         |          |
| Machine Weight        |                   |          |
| Capacity (Per Batch)  | ≥ 300 kg          |          |
| Price                 |                   |          |



## Moon Type Tea Rolling Machine (Granular Type Tea)

| Model         | DL-6CRT-30W      |
|---------------|------------------|
| Dimension     | 1050x950x1700 mm |
| Voltage       | 380V 50Hz        |
| Disc Diameter | 800 mm           |
| Drum Diameter | 300 mm           |
| Power         | 2 KW             |
| Motor Speed   | 1400 rpm         |
| Motor Voltage | 380V             |
| Drum Speed    | 42 RPM           |
| Price         |                  |



## Tea Lump Breaking Machine (After Rolling Step)

|               |                 |                 |
|---------------|-----------------|-----------------|
| Model         | DL-6CJK-40B     | DL-6CJK-60L     |
| Dimension     | 1160×510×1050mm | 980×1360×770 mm |
| Voltage       | 220/380V 50Hz   | 220/380V 50Hz   |
| Drum Diameter | 40 cm           | 60 cm           |
| Motor Power   | 0.55 KW         | 0.55 KW         |
| Motor Speed   | 1400 rpm        | 1400 rpm        |
| Materials     | Stainless Steel | Stainless Steel |
| Price         |                 |                 |



## Other Types Tea Rolling Machine (Customized Styles)



# 茶叶发酵设备

## TEA Oxidation/Fermentation EQUIPMENTS



## Intelligent Tea Fermentation Machine

|                     |                          |                 |
|---------------------|--------------------------|-----------------|
| Model               | DL-6CFJ-20               | DL-6CFJ-20QB    |
| Inner Materials     | Stainless Steel          | Stainless Steel |
| Out Board Materials | Painted Steel Board      | Stainless Steel |
| Dimension           | 770×700×1450 mm          |                 |
| Voltage             | 220/50 V/Hz              |                 |
| Heating Element     | Heating Wire             |                 |
| Heating Power       | 3.3 KW                   |                 |
| Heating Element Qty | 1 Group                  |                 |
| Blower Fan          | Power                    | 60 W            |
|                     | Speed                    | 2200 rpm        |
|                     | Voltage                  | 220 V           |
| Tray Size           | 600×400×100 mm           |                 |
| Tray Quantity       | 5 pcs (5 layers × 1 pcs) |                 |
| Capacity            | 40 kg/batch              |                 |
| Price               |                          |                 |



|                     |                          |                 |
|---------------------|--------------------------|-----------------|
| Model               | DL-6CFJ-60               | DL-6CFJ-60QB    |
| Inner Materials     | Stainless Steel          | Stainless Steel |
| Out Board Materials | Painted Steel Board      | Stainless Steel |
| Dimension           | 1000×1000×2200 mm        |                 |
| Voltage             | 220/50 V/Hz              |                 |
| Heating Element     | Heating Wire             |                 |
| Heating Power       | 6.0 KW                   |                 |
| Heating Element Qty | 1 Group                  |                 |
| Blower Fan          | Power                    | 85 W            |
|                     | Speed                    | 2200 rpm        |
|                     | Voltage                  | 220 V           |
| Tray Size           | 600×400×100 mm           |                 |
| Tray Quantity       | 16 pcs (8 layers × 2pcs) |                 |
| Capacity            | 130 kg/batch             |                 |
| Price               |                          |                 |



|                     |                          |                 |
|---------------------|--------------------------|-----------------|
| Model               | DL-6CFJ-80               | DL-6CFJ-80QB    |
| Inner Materials     | Stainless Steel          | Stainless Steel |
| Out Board Materials | Painted Steel Board      | Stainless Steel |
| Dimension           | 1600×1000×2200 mm        |                 |
| Voltage             | 220/50 V/Hz              |                 |
| Heating Element     | Heating Wire             |                 |
| Heating Power       | 6.0 KW                   |                 |
| Heating Element Qty | 1 Group                  |                 |
| Blower Fan          | Power                    | 85 W            |
|                     | Speed                    | 2200 rpm        |
|                     | Voltage                  | 220 V           |
| Tray Size           | 600×400×100 mm           |                 |
| Tray Quantity       | 32 pcs (8 layers × 4pcs) |                 |
| Capacity            | 250 kg/batch             |                 |
| Price               |                          |                 |



## Gaba (γ GAMMA) Tea Non-Oxygen Fermentation Tank

|                               |                   |
|-------------------------------|-------------------|
| Model                         | DL-6CFJT-15070    |
| Dimension                     | 2200×1350×2100 mm |
| Voltage                       | 220V 50Hz         |
| Power                         | 3 KW              |
| Injeet Nitrogen Concentration | 99%               |
| Drum Diameter                 | 715 mm            |
| Drum Length                   | 1500 mm           |
| Drum Pressure                 | 0.6 MPa           |
| Min Drum Pressure             | 100 PA            |
| Capacity                      | 200 kg/batch      |
| Price                         |                   |



# 茶叶成型设备

## TEA SHAPING EQUIPMENTS

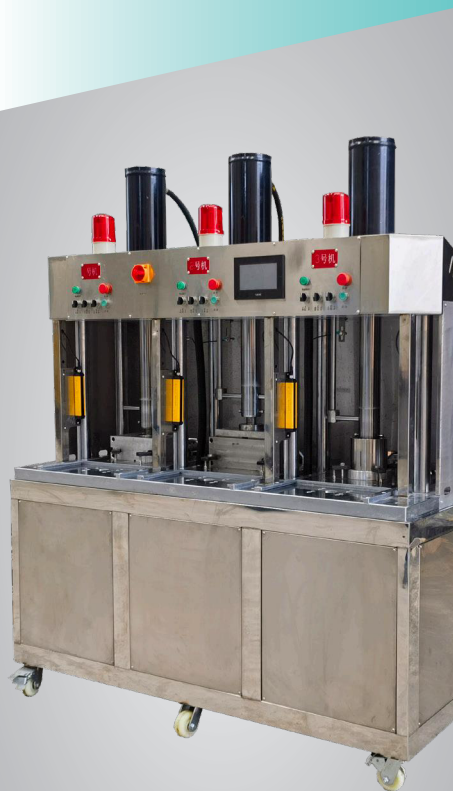

## Tea Cake/Brick Press Machine (Manual Discharge)

| Model                   | DL-6CY1-15                               | DL-6CY2-15       | DL-6CY3-15       |
|-------------------------|--|------------------|------------------|
| Dimension               | 700×760×1700 mm                          | 1200×760×1700 mm | 1710×760×1700 mm |
| Voltage                 | 380v 50hZ                                | 380v 50hZ        | 380v 50hZ        |
| Pressing Stroke         | ≥200 mm                                  | ≥200 mm          | ≥200 mm          |
| Press Type              | Hydraulic                                | Hydraulic        | Hydraulic        |
| Number Of Station       | 1  | 2                | 3                |
| Max Pressure            | 15 tons                                  | 15 tons          | 15 tons          |
| Power                   | 3 kW                                     | 3 kW             | 3 kW             |
| Motor Speed             | 1400 r/min                               | 1400 r/min       | 1400 r/min       |
| Motor Voltage           | 380 V                                    | 380 V            | 380 V            |
| Discharge Type          | Manual                                   |                  |                  |
| Suitable Tea Cake Range | Tea Cake/Bricks Which More Than 50 Grams |                  |                  |
| Capacity                | 60 Time/hour                             | 120 Time/hour    | 180 Time/hour    |
| Price                   |  |                  |                  |



## Tea Cake/Brick Press Machine (Automatic Discharge)

| Model                   | DL-6CY1-30Z                     | DL-6CY2-30Z       | DL-6CY3-30Z       |
|-------------------------|---------------------------------|-------------------|-------------------|
| Dimension               | 720×2100×2150 mm                | 1260×2100×2150 mm | 1800×2100×2150 mm |
| Voltage                 | 380V 50Hz                       | 380V 50Hz         | 380V 50Hz         |
| Pressing Stroke         | ≥200 mm                         | ≥200 mm           | ≥200 mm           |
| Press Type              | Hydraulic                       | Hydraulic         | Hydraulic         |
| Number Of Station       | 1                               | 2                 | 3                 |
| Max Pressure            | 30 tons                         | 30 tons           | 30 tons           |
| Power                   | 3 kW                            | 3 kW              | 3 kW              |
| Motor Speed             | 1400 r/min                      | 1400 r/min        | 1400 r/min        |
| Motor Voltage           | 380 V                           | 380 V             | 380 V             |
| Discharge Type          | Automatic Lifting And Discharge |                   |                   |
| Suitable Tea Cake Range | All Size Tea Cake/Bricks        |                   |                   |
| Capacity                | 60 Time/hour                    | 120 Time/hour     | 180 Time/hour     |
| Price                   |                                 |                   |                   |



## Steam Generator

| Model             | DL-6CZQ-6     | DL-6CZQ-12  | DL-6CZQ-24  | DL-6CZQ-36  |
|-------------------|---------------|-------------|-------------|-------------|
| Dimension         | 60×35×74 cm   | 67×40×75 cm | 73×45×80 cm | 73×45×80 cm |
| Voltage           | 220/380V 50Hz | 380V 50Hz   | 380V 50Hz   | 380V 50Hz   |
| Power             | 6KW           | 12KW        | 24KW        | 36KW        |
| Water Consumption | 8kg/h         | 16kg/h      | 32kg/h      | 48kg/h      |
| Steam Pressure    | 0.4-0.7Mpa    | 0.4-0.7Mpa  | 0.4-0.7Mpa  | 0.4-0.7Mpa  |
| Steam Temperature | 150°C-170°C   | 150°C-170°C | 150°C-170°C | 150°C-170°C |
| Water Tank Volume | 18L           | 20L         | 28L         | 28L         |
| Weight            | 50KG          | 65KG        | 70KG        | 70KG        |
| Price             |               |             |             |             |

## Steaming Tea Table

| Model            | DL-6CZQZ-7012   |
|------------------|-----------------|
| Dimension        | 1200×600×650 mm |
| Station Quantity | 2 pcs           |
| Materials        | Stainless Steel |
| Working Type     | Manual          |
| Weight           | 26 kg           |
| Price            |                 |



## Full Automatic Tea Cake/Ball/Brick Press Machine

|                  |   |          |
|------------------|---|----------|
| Model            | DL-6CYL-800                                   |          |
| Dimension        | 1100×1000×1650 mm                             |          |
| Voltage          | 380V 50Hz                                     |          |
| Power            | 9.0KW   |          |
| Press Type       | Electric + Air Cylinder                       |          |
| Scale Quantity   | 4 pcs   |          |
| Station Quantity | 2 pcs   |          |
| Discharge Type   | Automatic Discharge<br>1 Time Press Get 2 pcs |          |
| Weight Error     | ±0.2g   |          |
| Capacity         | 800-1000 pcs/hour                             |          |
| Model Materials  | SS 304  |          |
| Final Tea Size   | Square Tea Cake Size                          | 25-40 mm |
|                  | Round Tea Cake Size                           | 25-45 mm |
|                  | Ball Type Tea Size                            | 27-35 mm |
| Price            |   |          |



## Double Pot Tea Roaster (Gunpowder Tea Machine)

| Model              | DL-6CSG-50       | DL-6CSG-60       | DL-6CSG-84       |
|--------------------|------------------|------------------|------------------|
| Dimension          | 1800×800×1050 mm | 2000×900×1150 mm | 1800×800×1050 mm |
| Voltage            | 380V 50Hz        | 380V 50Hz        | 380V 50Hz        |
| Heating Type       | Heating Wire     | Heating Wire     | Heating Wire     |
| Heating Power      | 7.6 kw           | 13 kw            | 15 kw            |
| Swing Motor Power  | 0.75 kW × 2      | 0.75 kW × 2      | 1.5 kW × 2       |
| Blower Motor Power | 0.15 kW × 2      | 0.15 kW × 2      | 120W × 2         |
| Pot Quantity       | 2                | 2                | 2                |
| Swing Speed Grade  | 2 (Fast / Slow)  | 2 (Fast / Slow)  | Stepless Speed   |
| Pot Diameter       | 500 mm           | 600 mm           | 84cm             |
| 2 Pots Capacity    | 8-10 kg          | 12-16 kg         | 70-80 kg         |
| Price              |                  |                  |                  |



## Flat Type Tea Press Shaping Machine (LongJing Tea)

|               |                  |  |
|---------------|------------------|--|
| Model         | DL-6CBC-891ZD    |  |
| Dimension     | 1428×795×1190 mm |  |
| Voltage       | 220V 50Hz        |  |
| Heating Type  | Heating Wire     |  |
| Heating Power | 5 kw             |  |
| Motor Power   | 0.75 KW          |  |
| Pot Size      | 900×480×184 mm   |  |
| Pot Materials | Stainless Steel  |  |
| Press Speed   | 29-32 RPM        |  |
| Capacity      | 500 gram / hour  |  |
| Price         |                  |  |



## Tea Carding Shaping Machine (Needle Shape Tea Machine)

| Model               | DL-6CLT-8012D    | DL-6CLT-8012Q    |
|---------------------|------------------|------------------|
| Dimension           | 1600×1020×870 mm | 1600×1020×870 mm |
| Voltage             | 380V 50Hz        | 220/380V 50Hz    |
| Heating Type        | Electric         | Gas              |
| Heating Power       | 24 KW            | /                |
| Heating Element Qty | 8 Group          | 7 Group          |
| Swing Motor Power   | 1.1 KW           | 1.1 KW           |
| Fan Motor Power     | 120 W            | 120 W            |
| Swing Speed         | 5-35 rpm         | 5-35 rpm         |
| Groove Size         | 10×800 mm        | 10×800 mm        |
| Groove Qty          | 12               | 12               |
| Capacity            | 2 kg/batch       | 2 kg/batch       |
| Price               |                  |                  |



## Granular Tea Canvas Warring Machine

|                                |                  |
|--------------------------------|------------------|
| Model                          | DL-6CSBG-20      |
| Dimensions                     | 1060×630×1010 mm |
| Voltage                        | 380V 50Hz        |
| Rubbed stick height            | 220 mm           |
| Lead Screw Drive Motor Power   | 0.75 kW          |
| Rubbed Stick Drive Motor Power | 1.1 kW           |
| Output per hour                | 100 Kg/h         |
| Price                          |                  |



## Granular Tea Canvas Rolling Machine

|                                  |                |
|----------------------------------|----------------|
| Model                            | DL-6CBRP-70    |
| Input Power                      | 380V/HZ        |
| Dimensions                       | 710×710×1320mm |
| Rolling disc diameter            | 700mm          |
| Rolling Disc Drive Motor Power   | 1.1kW          |
| Rolling Disc up/down Motor Power | 0.38kW         |
| Price                            |                |



## Hot Air Tea Lump Block Breaking Machine

|                                      |                   |
|--------------------------------------|-------------------|
| Model                                | DL-6CSST-100R     |
| Dimension                            | 1750×1450×1570 mm |
| Voltage                              | 380V 50Hz         |
| Drum Diameter                        | 1000 mm           |
| Drum Length                          | 1000 mm           |
| Motor Power                          | 0.75 kW           |
| Total heating power                  | 18 kW             |
| Speed of barrel                      | 36 r/min          |
| Diameter of sieve(Can be customized) | 2 mm              |
| Price                                |                   |



## Semi-Automatic Granular Tea Press Shaping Machine

|                                  |                   |
|----------------------------------|-------------------|
| Model                            | 6CCXJ-6080        |
| Dimensions                       | 1760×1870×1600 mm |
| Inner cavity size                | 800×600×250 mm    |
| Minimum size of material molding | 300×100×250 mm    |
| Pressurization method            | Hydraulic         |
| Maximum pressure                 | 16 MPa            |
| Driving power                    | 5.5 kW            |
| Motor speed                      | 1400 r/min        |
| Rated Voltage                    | 380 V             |
| Price                            |                   |



## Full Automatic Granular Shape Tea Shaping Group

|                                  |                  |
|----------------------------------|------------------|
| Model                            | 6CCXJ-6585L      |
| Input power                      | 380/50V/HZ       |
| Dimensions                       | 2250×1850×1780mm |
| Inner cavity size (L×W×H)        | 650×500×850mm    |
| Minimum size of material molding | 250×150×270mm    |
| Pressurization method            | Hydraulic        |
| Maximum pressure                 | 20MPa            |
| Driving power                    | 7.5kW            |
| Motor speed                      | 1400r/min        |
| Rated Voltage                    | 380V             |
| Price                            |                  |



# 食品茶叶烘干设备

## FOOD & TEA DRYING EQUIPMENTS



## F Series Square Tray Baking Cabinet Machine

| Model         | DL-6CH-2F           | DL-6CH-3F           | DL-6CH-5F           |
|---------------|---------------------|---------------------|---------------------|
| Dimension     | 670×560×1380 mm     | 770×680×1610 mm     | 1070×810×1880 mm    |
| Voltage       | 220V 50Hz           | 220V 50Hz           | 380V 50Hz           |
| Heating Power | 2.48 m <sup>2</sup> | 6.55 m <sup>2</sup> | 9.55 m <sup>2</sup> |
| Heating Type  | Electric Heating    |                     |                     |
| Drying Area   | 1.8                 | 3.38                | 5.76                |
| Tray Size     | 400×500×40 mm       | 580×530×40 mm       | 600×600×40 mm       |
| Drying Layers | 9                   | 12                  | 16                  |
| Price         |                     |                     |                     |



## Square Tray Baking Cabinet Machine

| Model         | DL-6CH-1            | DL-6CH-2            | DL-6CH-3            | DL-6CH-6            | DL-6CH-12            |
|---------------|---------------------|---------------------|---------------------|---------------------|----------------------|
| Dimension     | 600×490×1100 mm     | 670×560×1400 mm     | 780×680×1680 mm     | 880×780×2100 mm     | 1420×1100×2190 mm    |
| Voltage       | 220V 50Hz           | 220V 50Hz           | 220V 50Hz           | 380V 50Hz           | 380V 50Hz            |
| Heating Power | 2.18 m <sup>2</sup> | 3.18 m <sup>2</sup> | 6.55 m <sup>2</sup> | 9.33 m <sup>2</sup> | 15.55 m <sup>2</sup> |
| Heating Type  | Electric Heating    |                     |                     |                     |                      |
| Drying Area   | 0.8                 | 1.8                 | 3                   | 5.76                | 11.83                |
| Tray Size     | 320×435×30 mm       | 400×500×30 mm       | 500×500×30 mm       | 600×600×30 mm       | 860×860×30 mm        |
| Drying Layers | 6                   | 9                   | 12                  | 16                  | 16                   |
| Price         |                     |                     |                     |                     |                      |



## Hot Air Drum Type Revolving Drying Machine

| Model         | DL-6CHDT-80       | DL-6CHDT-100      | DL-6CHDT-120      |
|---------------|-------------------|-------------------|-------------------|
| Dimension     | 6600×1080×2300 mm | 7600×1280×2560 mm | 8600×1480×2860 mm |
| Voltage       | 380V 50Hz         | 380V 50Hz         | 380V 50Hz         |
| Drive Motor   | Power             | 1.5 kW            | 2.2 kW            |
|               | Speed             | 1400 rpm          | 1400 rpm          |
|               | Voltage           | 380V              | 380V              |
| Drum Diameter | 80 cm             | 100 cm            | 120 cm            |
| Drying Type   | Hot Air           |                   |                   |
| Price         |                   |                   |                   |

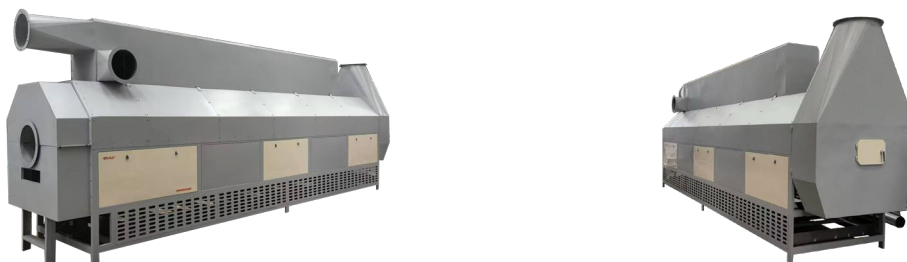

## Rotate Type Tea Drying Cabinet Machine (Electric Heating)

| Model                 | DL-6CHZ-2             | DL-6CHZ-2B          | DL-6CHZ-2QB     |
|-----------------------|-----------------------|---------------------|-----------------|
| Tray Materials        | Stainless Steel       | Stainless Steel     | Stainless Steel |
| Inner Board Materials | Galvanized Steel      | Stainless Steel     | Stainless Steel |
| Outer Board Materials | Painted Steel Board   | Painted Steel Board | Stainless Steel |
| Dimension             | 750x700x1550 mm       |                     |                 |
| Voltage               | 220V 50Hz             |                     |                 |
| Heating Type          | Electric Heating Wire |                     |                 |
| Heating Power         | 5.0 KW                |                     |                 |
| Heating Element Qty   | 1 Group               |                     |                 |
| Fan Motor Power       | 0.18 KW               |                     |                 |
| Tray Motor Power      | 15 W                  |                     |                 |
| Tray Rotate Speed     | 6 rpm                 |                     |                 |
| Tray Shape            | Round                 |                     |                 |
| Tray Layers           | 10 Layers             |                     |                 |
| Tray Diameter         | 48-50cm               |                     |                 |
| Effective Drying Area | 1.96 m <sup>2</sup>   |                     |                 |
| Capacity Per Batch    | 6-8 kg/batch          |                     |                 |
| Price                 |                       |                     |                 |



| Model                 | DL-6CHZ-5             | DL-6CHZ-5B          | DL-6CHZ-5QB     |
|-----------------------|-----------------------|---------------------|-----------------|
| Tray Materials        | Stainless Steel       | Stainless Steel     | Stainless Steel |
| Inner Board Materials | Galvanized Steel      | Stainless Steel     | Stainless Steel |
| Outer Board Materials | Painted Steel Board   | Painted Steel Board | Stainless Steel |
| Dimension             | 1080x1100x2000 mm     |                     |                 |
| Voltage               | 220/380V 50Hz         |                     |                 |
| Heating Type          | Electric Heating Wire |                     |                 |
| Heating Power         | 9 kw                  |                     |                 |
| Heating Element Qty   | 3 Group               |                     |                 |
| Fan Motor Power       | 0.55 kw               |                     |                 |
| Tray Motor Power      | 30 W                  |                     |                 |
| Tray Rotate Speed     | 6 rpm                 |                     |                 |
| Tray Shape            | Round                 |                     |                 |
| Tray Layers           | 14 Layers             |                     |                 |
| Tray Diameter         | 68-70cm               |                     |                 |
| Effective Drying Area | 5.38 m <sup>2</sup>   |                     |                 |
| Capacity Per Batch    | 15-20 kg/batch        |                     |                 |
| Price                 |                       |                     |                 |



| Model                 | DL-6CHZ-9             | DL-6CHZ-9B          | DL-6CHZ-9QB     |
|-----------------------|-----------------------|---------------------|-----------------|
| Tray Materials        | Stainless Steel       | Stainless Steel     | Stainless Steel |
| Inner Board Materials | Galvanized Steel      | Stainless Steel     | Stainless Steel |
| Outer Board Materials | Painted Steel Board   | Painted Steel Board | Stainless Steel |
| Dimension             | 1200x1100x2200 mm     |                     |                 |
| Voltage               | 380V 50Hz             |                     |                 |
| Heating Type          | Electric Heating Wire |                     |                 |
| Heating Power         | 15 kw                 |                     |                 |
| Heating Element Qty   | 3 Group               |                     |                 |
| Fan Motor Power       | 0.55 kw               |                     |                 |
| Tray Motor Power      | 40 W                  |                     |                 |
| Tray Rotate Speed     | 6 rpm                 |                     |                 |
| Tray Shape            | Round                 |                     |                 |
| Tray Layers           | 16 Layers             |                     |                 |
| Tray Diameter         | 88-90cm               |                     |                 |
| Effective Drying Area | 10.1 m <sup>2</sup>   |                     |                 |
| Capacity Per Batch    | 27-36 kg/batch        |                     |                 |
| Price                 |                       |                     |                 |



## Rotate Type Tea Drying Cabinet Machine (Electric Heating)

|                       |                        |                     |                 |
|-----------------------|------------------------|---------------------|-----------------|
| Model                 | DL-6CHZ-14             | DL-6CHZ-14B         | DL-6CHZ-14QB    |
| Tray Materials        | Stainless Steel        | Stainless Steel     | Stainless Steel |
| Inner Board Materials | Galvanized Steel Board | Stainless Steel     | Stainless Steel |
| Outer Board Materials | Painted Steel Board    | Painted Steel Board | Stainless Steel |
| Dimension             | 1400x1320x2300 mm      |                     |                 |
| Voltage               | 380V 50Hz              |                     |                 |
| Heating Type          | Electric Heating Wire  |                     |                 |
| Heating Power         | 18 kw                  |                     |                 |
| Heating Element Qty   | 3 Group                |                     |                 |
| Fan Motor Power       | 0.75 KW                |                     |                 |
| Tray Motor Power      | 60 W                   |                     |                 |
| Tray Rotate Speed     | 6 rpm                  |                     |                 |
| Tray Shape            | Round                  |                     |                 |
| Tray Layers           | 16 Layers              |                     |                 |
| Tray Diameter         | 108-110cm              |                     |                 |
| Effective Drying Area | 14.6 m <sup>2</sup>    |                     |                 |
| Capacity Per Batch    | 42-56 kg/batch         |                     |                 |
| Price                 |                        |                     |                 |



|                       |                        |                     |                 |
|-----------------------|------------------------|---------------------|-----------------|
| Model                 | DL-6CHZ-34             | DL-6CHZ-34B         | DL-6CHZ-34QB    |
| Tray Materials        | Stainless Steel        | Stainless Steel     | Stainless Steel |
| Inner Board Materials | Galvanized Steel Board | Stainless Steel     | Stainless Steel |
| Outer Board Materials | Painted Steel Board    | Painted Steel Board | Stainless Steel |
| Dimension             | 2600×1800×2900 mm      |                     |                 |
| Voltage               | 380V 50Hz              |                     |                 |
| Heating Type          | Electric Heating Wire  |                     |                 |
| Heating Power         | 36 KW                  |                     |                 |
| Heating Element Qty   | 6 Group                |                     |                 |
| Fan Motor Power       | 3 KW                   |                     |                 |
| Tray Motor Power      | 80 W                   |                     |                 |
| Tray Rotate Speed     | 6 rpm                  |                     |                 |
| Tray Shape            | Round                  |                     |                 |
| Tray Layers           | 36 Layers              |                     |                 |
| Tray Diameter         | 108-110cm              |                     |                 |
| Effective Drying Area | 34.2 m <sup>2</sup>    |                     |                 |
| Capacity Per Batch    | 100-135 kg/batch       |                     |                 |
| Price                 |                        |                     |                 |



6CHZ-B Series  
Inside All SS



Computer Board  
Control Box



6CHZ-QB Series  
All SS Type

## Rotate Type Tea Drying Cabinet Machine (Electric & Gas Heating)

| Model                   | DL-6CHZ-QD14            | DL-6CHZ-QD14B       | DL-6CHZ-QD14QB  |
|-------------------------|-------------------------|---------------------|-----------------|
| Tray Materials          | Stainless Steel         | Stainless Steel     | Stainless Steel |
| Inner Board Materials   | Galvanized Steel        | Stainless Steel     | Stainless Steel |
| Outer Board Materials   | Painted Steel Board     | Painted Steel Board | Stainless Steel |
| Dimension               | 1693×1310×2290 mm       |                     |                 |
| Voltage                 | 220/380V 50Hz           |                     |                 |
| Heating Type            | Gas + Electric (Hybird) |                     |                 |
| Electric Heating Power  | 24 KW                   |                     |                 |
| Fan Motor Power         | 0.55 KW                 |                     |                 |
| Tray Rotate Motor Power | 60 W                    |                     |                 |
| Tray Speed              | 6 rpm                   |                     |                 |
| Tray Shape              | Round                   |                     |                 |
| Tray Diameter           | 108-110cm               |                     |                 |
| Tray Quantity           | 16 Layers               |                     |                 |
| Effective Drying Area   | 14.6 m <sup>2</sup>     |                     |                 |
| Capacity Per Batch      | 42-56 kg/batch          |                     |                 |
| Price                   |                         |                     |                 |



| Model                   | DL-6CHZ-QD18            | DL-6CHZ-QD18B       | DL-6CHZ-QD18QB  |
|-------------------------|-------------------------|---------------------|-----------------|
| Tray Materials          | Stainless Steel         | Stainless Steel     | Stainless Steel |
| Inner Board Materials   | Galvanized Steel        | Stainless Steel     | Stainless Steel |
| Outer Board Materials   | Painted Steel Board     | Painted Steel Board | Stainless Steel |
| Dimension               | 1793×1410×2290 mm       |                     |                 |
| Voltage                 | 220/380V 50Hz           |                     |                 |
| Heating Type            | Gas + Electric (Hybird) |                     |                 |
| Electric Heating Power  | 24 KW                   |                     |                 |
| Fan Motor Power         | 0.55 KW                 |                     |                 |
| Tray Rotate Motor Power | 60 W                    |                     |                 |
| Tray Speed              | 6 rpm                   |                     |                 |
| Tray Shape              | Round                   |                     |                 |
| Tray Diameter           | 118-120cm               |                     |                 |
| Tray Quantity           | 16 Layers               |                     |                 |
| Effective Drying Area   | 18.1 m <sup>2</sup>     |                     |                 |
| Capacity Per Batch      | 54-72 kg/batch          |                     |                 |
| Price                   |                         |                     |                 |



Gas Burner



Quick Exhaust Fan

## Electric Heating Small Tea Baking Drum (Bamboo)

| Model                  | DL-6CHBL-20 | DL-6CHBL-25 | DL-6CHBL-40 | DL-6CHBL-50 | DL-6CHBL-60 | DL-6CHBL-70 |
|------------------------|-------------|-------------|-------------|-------------|-------------|-------------|
| Capacity               | ≤500g       | ≤1000g      | ≤2000g      | ≤2500g      | ≤3000g      | ≤7500g      |
| Temp Range             | 30-150 °C   | 30-150 °C   | 30-150 °C   | 30-150 °C   | 30-150 °C   | 30-150 °C   |
| Voltage                | 160-230V    | 160-230V    | 160-230V    | 160-230V    | 160-230V    | 160-230V    |
| Power                  | 400W        | 400W        | 900W        | 1100W       | 1200W       | 1800W       |
| Size                   | 22×22×25cm  | 29×29×34cm  | 40×40×46cm  | 54×54×54cm  | 63×63×63cm  | 72×72×62cm  |
| Drum size              | 20×20×15cm  | 25×25×21cm  | 37×37×30cm  | 50×50×38cm  | 58×58×43cm  | 65×65×47cm  |
| Heating plate diameter | 17cm        | 22cm        | 34cm        | 48cm        | 54cm        | 60cm        |
| Packing size           | 22×23×26cm  | 32×32×35cm  | 41×41×47cm  | 56×56×56cm  | 65×65×64cm  | 74×74×64cm  |
| Weight                 | 1.8 kgs     | 2.8 kgs     | 4.6 kgs     | 8 kgs       | 12 kgs      | 20 kgs      |
| Price                  |             |             |             |             |             |             |



Control Panel



Electric Heating System

## Chain Plate Type Tea Drying Machine

| Model                          | DL-6CHBZ-8   | DL-6CHBZ-10       | DL-6CHBZ-16       | DL-6CHBZ-20       | DL-6CHBZ-30       |
|--------------------------------|--|-------------------|-------------------|-------------------|-------------------|
| Drying Box Dimension           | 3335×1560×1535 mm                                    | 3335×1910×1535 mm | 4790×1910×2050 mm | 5600×1910×2050 mm | 6335×2220×2300 mm |
| Voltage                        | 220V/380V 50Hz                                       | 220V/380V 50Hz    | 220V/380V 50Hz    | 220V/380V 50Hz    | 220V/380V 50Hz    |
| Power                          | 4.7 KW   | 4.7 KW            | 8.8 KW            | 8.8 KW            | 8.8 KW            |
| Drying Layers                  | 6Layers  | 6Layers           | 6Layers           | 6Layers           | 8Layers           |
| Heating Fuel                   | Wood / Coal / Gas / Diesel / Wood Pellets / Electric |                   |                   |                   |                   |
| Chain Plate Size               | 1000×108 mm  | 1212×108 mm       | 1212×108 mm       | 1212×108 mm       | 1515×108 mm       |
| Drying Area                    | 8m <sup>2</sup>                                      | 10m <sup>2</sup>  | 16m <sup>2</sup>  | 20m <sup>2</sup>  | 30m <sup>2</sup>  |
| Input Wet Tea Moisture         | ≈ 50%  |                   |                   |                   |                   |
| Output Dried Tea Moisture      | ≈ 5-7%   |                   |                   |                   |                   |
| Inout Wet Tea Weight           | 30 kg  | 40 kg             | 90 kg             | 100 kg            | 190 kg            |
| Output Dried Tea Weight        | 18 kg  | 22 kg             | 50 kg             | 55 kg             | 100 kg            |
| Price (Galvanized Steel Plate) |  |                   |                   |                   |                   |
| Price (SS Chain Plate)         |  |                   |                   |                   |                   |

| Model                          | DL-6CHBZ-40                               | DL-6CHBZ-50       | DL-6CHBZ-60       | DL-6CHBZ-80       | DL-6CHBZ-100       | DL-6CHBZ-120       |
|--------------------------------|---|-------------------|-------------------|-------------------|--------------------|--------------------|
| Drying Box Dimension           | 6715×2235×2300 mm                         | 8215×2025×3025 mm | 8500×2025×3025 mm | 9200×2320×3420 mm | 10100×2320×3420 mm | 11000×2320×3420 mm |
| Voltage                        | 380V 50Hz                                 | 380V 50Hz         | 380V 50Hz         | 380V 50Hz         | 380V 50Hz          | 380V 50Hz          |
| Power                          | 8.8 KW                                    | 13 KW             | 13 KW             | 15 KW             | 15 KW              | 15 KW              |
| Drying Layers                  | 8Layers                                   | 10Layers          | 10Layers          | 12Layers          | 12Layers           | 12Layers           |
| Heating Fuel                   | Wood / Coal / Gas / Diesel / Wood Pellets |                   |                   |                   |                    |                    |
| Chain Plate Size               | 1515×108 mm                               | 1515×108 mm       | 1515×108 mm       | 1800×108 mm       | 1800×108 mm        | 1800×108 mm        |
| Drying Area                    | 40m <sup>2</sup>                          | 50m <sup>2</sup>  | 60m <sup>2</sup>  | 80m <sup>2</sup>  | 100m <sup>2</sup>  | 120m <sup>2</sup>  |
| Input Wet Tea Moisture         | ≈ 50%                                     |                   |                   |                   |                    |                    |
| Output Dried Tea Moisture      | ≈ 5-7%                                    |                   |                   |                   |                    |                    |
| Inout Wet Tea Weight           | 290 kg                                    | 420 kg            | 570 kg            | 760 kg            | 1000 kg            | 1300 kg            |
| Output Dried Tea Weight        | 150 kg                                    | 220 kg            | 300 kg            | 400 kg            | 550 kg             | 700 kg             |
| Price (Galvanized Steel Plate) |   |                   |                   |                   |                    |                    |
| Price (SS Chain Plate)         |   |                   |                   |                   |                    |                    |



### Wood / Coal / Wood Pellets Heating Type



## Top Blowing Gas/Diesel Heating Type



## Electric Heating Type

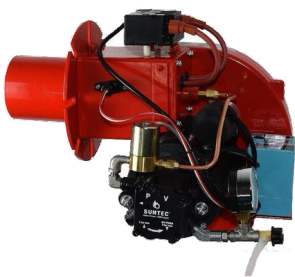

Gas / Diesel Burner



LPG/LNG Gasifier



Wood/Coal Stove

## Down Blowing Type Winnowing Sorting Machine

|                    |                           |
|--------------------|---------------------------|
| Model              | DL-6CFX-F30-3             |
| Voltage            | 220V 50HZ                 |
| Dimension          | 1200×1000×1330 mm         |
| Speed Control Mode | Stepless Speed Regulation |
| Machine Weight     | 62 kgs                    |
| Capacity           | 100 kg/h                  |
| Price              |                           |



## Small Vibration Sorting Machine

|                    |                 |
|--------------------|-----------------|
| Model              | DL-6CDS-100-3   |
| Voltage            | 220V 50Hz       |
| Working type       | Reciprocating   |
| Size               | 1400×650×1050mm |
| Outlet number      | 3               |
| Sieve plate number | 3 pcs           |
| Sieve plate size   | 900×450 mm      |
| Motor power        | 0.18 kw         |
| Price              |                 |



## Small Vibration & Winnowing Sorting Machine

|                     |                 |            |
|---------------------|-----------------|------------|
| Model               | DL-6CFX-435QB   |            |
| Dimensions          | 980×520×1190 mm |            |
| voltage / frequency | 220/50 V/HZ     |            |
| Total Power         | 300 W           |            |
| Grade               | 4 Level         |            |
| Weight              | 55 KG           |            |
| Fan power           | 0.12 kW         |            |
| Motor speed         | 1500 r/min      |            |
| Rated voltage       | 220 V           |            |
| Vibration Motor     | power           | 0.18 kW    |
|                     | Rotating speed  | 1400 r/min |
|                     | Rated voltage   | 220 V      |
| Price               |                 |            |



## Continuous Type Tea Winnowing Sorting Machine

|                        |                      |
|------------------------|----------------------|
| Model                  | DL-6CFX-40           |
| Dimensions             | 4080×760×2130 mm     |
| voltage / frequency    | 380/50 V/Hz          |
| Feeding method         | Hoister              |
| Grade                  | 4 Level              |
| Fan speed control mode | YCT speed regulation |
| Fan power              | 1.5 kW               |
| Motor speed            | 1400 r/min           |
| Rated voltage          | 380 V                |
| Hoist Power            | 1.1 kW               |
| Lifting Height         | 1560 mm              |
| Conoveying Bandwidth   | 225 mm               |
| Output per hour        | 500 Kg/h             |
| Price                  |                      |



# 茶叶精加工设备

## TEA SORTING & CLEANING EQUIPMENTS



## High Frequency Vibration Screening Machine

| Model                  | DL-6CZXS-830  | DL-6CZXS-1040  | DL-6CZXS-1250  | DL-6CZXS-1560  |
|------------------------|---------------|----------------|----------------|----------------|
| Dimension              | 980×450×500mm | 1300×500×620mm | 1500×620×670mm | 1900×820×770mm |
| Voltage                | 220V / 380V   | 220V / 380V    | 220V / 380V    | 220V / 380V    |
| Power                  | 70w×2         | 120w×2         | 250w×2         | 250w×2         |
| Sieve Plate Size       | 800×300mm     | 1000×400mm     | 1200×500mm     | 1500×600mm     |
| Outlet Quantity        | 3             | 3              | 3              | 3              |
| Price Galvanized Steel |               |                |                |                |
| Price Stainless Steel  |               |                |                |                |



## Stepped Type Vibration Tea Stalk Picker Machine

|                     |                     |
|---------------------|---------------------|
| Model               | DL-6CJIG-80         |
| Working Type        | Step Vibration Type |
| Dimensions          | 1780×1050×1630 mm   |
| Voltage             | 220V 50Hz           |
| Power               | 0.55 kw             |
| Vibration frequency | 686-915 Hz          |
| Picking Width       | 820 mm              |
| Capacity            | 80~120 kg/h         |
| Weight              | 200 kg              |
| Price               |                     |



## Plane Circular Screening Machine

| Model           | DL-6CPYS-AK700       | DL-6CPYS-AK1000   |
|-----------------|----------------------|-------------------|
| Dimension       | 4100×1700×1950mm     | 4450×20100×2100mm |
| Voltage         | 380V 50Hz            |                   |
| Power           | 1.1KW                |                   |
| Working Type    | Planar Circular Type |                   |
| Layers          | 4 Layers             |                   |
| Outlet Qty      | 5 Outlets            |                   |
| Screen Angle    | 6.5 °                |                   |
| Rotation Radius | 30mm                 |                   |
| Rotate Speed    | 0-230 Rpm            |                   |
| Sieve Size      | 1700×700 mm          | 1700×1000 mm      |
| Capacity        | 400-500 kg/h         | 500-700 kg/h      |
| Price           |                      |                   |



## Arnot Shaking Type Sorting Bed Machine

| Model                  | DL-6CDS-300       | DL-6CDS-300QB |
|------------------------|-------------------|---------------|
| Dimension              | 5200×1200×2410 mm |               |
| Voltage                | 380V 50Hz         |               |
| Power                  | 1.5 kw            |               |
| Working Type           | Reciprocating     |               |
| Layers                 | 2 Layers          |               |
| Outlet                 | 3 Outlets         |               |
| Reciprocating Distance | 50 mm             |               |
| Sieve Bed Speed        | 250 rpm           |               |
| Capacity               | 200-300 kg/h      |               |
| Price                  |                   |               |



## Round Sieve Circular Vibration Screening Machine

| Model                  | DL-6CZDS-45         | DL-6CZDS-80        | DL-6CZDS-100        | DL-6CZDS-120        |
|------------------------|---------------------|--------------------|---------------------|---------------------|
| Voltage                | 220/380V 50Hz       | 220/380V 50Hz      | 220/380V 50Hz       | 380V 50Hz           |
| Power                  | 0.37kw              | 0.75kw             | 1.1kw               | 2.2kw               |
| Sieve Diameter         | 45cm                | 80cm               | 100cm               | 120cm               |
| Effective Sieve Area   | 0.09 m <sup>2</sup> | 0.4 m <sup>2</sup> | 0.63 m <sup>2</sup> | 0.95 m <sup>2</sup> |
| Materials Max Diameter | ≤ 10mm              | ≤ 10mm             | ≤ 10mm              | ≤ 10mm              |
| Sieve Size             | 2-325#              | 2-325#             | 2-325#              | 2-325#              |
| Layers                 | 1-5 layers          | 1-5 layers         | 1-5 layers          | 1-5 layers          |
| Vibration frequency    | 1500 rpm            | 1500 rpm           | 1500 rpm            | 1500 rpm            |
| Price                  |                     |                    |                     |                     |



## Electrostatic Dust Removal Cleaner Machine

| Model                    | DL-6CJDCZ-780-3   | DL-6CJDCZ-780-5   | DL-6CJDCZ-1350-8  |
|--------------------------|-------------------|-------------------|-------------------|
| Overall Dimensions       | 4300×1430×1700 mm | 5540×1340×1700 mm | 7470×2020×1730 mm |
| Sorting Bed Dimension    | 2310×1430×1700 mm | 3380×1340×1700 mm | 5310×2020×1730 mm |
| Conveyor Dimension       | 2100×1430×1700 mm | 2100×1430×1700 mm | 2160×2000×1730 mm |
| Voltage                  | 380V 50Hz         | 380V 50Hz         | 380V 50Hz         |
| Power                    | 1.5 kw            | 1.5 kw            | 2 kw              |
| Vibration Motor Quantity | 2 pcs             | 2 pcs             | 2 pcs             |
| Roller Length            | 780mm             | 780mm             | 1350mm            |
| Roller Quantity          | 3 pcs             | 5 pcs             | 8 pcs             |
| Clean Efficiency         | ≥ 90%             | ≥ 92%             | ≥ 96%             |
| Capacity                 | ≥ 300 kg/h        | ≥ 300 kg/h        | ≥ 400 kg/h        |
| Price                    |                   |                   |                   |



## Tea Color Sorting Machine

| Model                       | DL-6CSX-MT64     | DL-6CSX-T2C2      | DL-6CSX-T2C4      |
|-----------------------------|------------------|-------------------|-------------------|
| Dimension                   | 873×1587×1635 mm | 1560×2150×1982 mm | 2267×2150×1982 mm |
| Voltage                     | 380V 50Hz        | 380V 50Hz         | 380V 50Hz         |
| Layers                      | 1 Layer          | 2 Layers          | 2 Layers          |
| Machine Power               | 0.7 kW           | 3.9 kW            | 4.7 kW            |
| Air Compressor Power        | 7.5 kW           | 12 kW             | 22 kW             |
| Air Pressure                | 0.6-0.8 Mpa      | 0.6-0.8 Mpa       | 0.6-0.8 Mpa       |
| Accuracy                    | ≥ 99%            | ≥ 99%             | ≥ 99%             |
| Carryover Rate (Bad : Good) | > 30:1           | > 50:1            | > 50:1            |
| Output                      | ≤ 150 kg/h       | ≤ 300 kg/h        | ≤ 400 kg/h        |
| Price                       |                  |                   |                   |



## Dried Tea Leaf Crushing Machine

| Model                     | DL-6CCQ-63          | DL-6CCQ-63QB    | DL-6CCQ-263         | DL-6CCQ-263QB   |
|---------------------------|---------------------|-----------------|---------------------|-----------------|
| Board Materials           | Stainless Steel     | Stainless Steel | Stainless Steel     | Stainless Steel |
| Roller Materials          | Cast Iron           | Stainless Steel | Cast Iron           | Stainless Steel |
| Dimension                 | 950×1050×1450 mm    |                 | 950×1050×1450 mm    |                 |
| Voltage                   | 220/380V / 50HZ     |                 | 220/380V / 50HZ     |                 |
| Power                     | 0.75 kW             |                 | 1.5 kW              |                 |
| Roller Quantity           | 1 pcs               |                 | 2 pcs               |                 |
| Roller Diameter           | 96 mm               |                 | 96 mm               |                 |
| Roller Length             | 630 mm              |                 | 630 mm              |                 |
| Roller And Teeth Distance | 0.3 mm              |                 | 0.3 mm              |                 |
| Roller Teeth Distance     | 4/6/8/10/12/14/16mm |                 | 4/6/8/10/12/14/16mm |                 |
| Roller Speed              | 260 rpm             |                 | 260 rpm             |                 |
| Capacity                  | 300 kg/h            |                 | 500 kg/h            |                 |
| Price                     |                     |                 |                     |                 |



## Dried Tea Leaf Grinding Machine

|                |                     |
|----------------|---------------------|
| Model          | DL-PS-300T          |
| Dimension      | 800×650×1500mm      |
| Voltage        | 380V 50Hz           |
| Power          | 4KW                 |
| Motor Quantity | 2pcs                |
| Blade Quantity | 9pcs                |
| Final Tea Size | 1-20mm (Adjustable) |
| Roller Size    | 310×290mm           |
| Capacity       | 300kg/h             |
| Price          |                     |



## Tea Moisture Analyzer (Tea Moisture Meter)

|                           |   |
|---------------------------|---|
| Model Number              | DL-SFY-120                                    |
| Dimension                 | 310×205×200 mm                                |
| Voltage                   | 220V 50Hz                                     |
| Max. Capacity             | 120g  |
| Display index value       | 0.005g  |
| Readability               | 0.01%   |
| Heating source            | Ring-shaped halogen lamp                      |
| Heating temperature range | 40-200°C                                      |
| Weight calibration        | 100g  |
| Pan size                  | Φ90mm   |
| Sensor                    | Electromagnetic force sensor                  |
| Display                   | LCD   |
| Heating procedure         | Standard heating, Rapid heating, Step heating |
| Power-off mode            | Time-off, Auto-off, Manual-off                |
| Heating time range        | 1-99 minutes                                  |
| Price                     |   |



## Matcha Tea Grinder (Matcha Stone Miller)

|                |                 |              |                |                |                |
|----------------|-----------------|--------------|----------------|----------------|----------------|
| Model          | DL-6CYM-30      | DL-6CYM-50   | DL-6CYM-70     | DL-6CYM-90     | DL-6CYM-110    |
| Dimension      | 55×52×90 cm     | 95×92×118 cm | 115×112×133 cm | 135×132×140 cm | 144×143×155 cm |
| Voltage        | 220/380V 50Hz   |              |                |                |                |
| Power          | 0.75 kw         | 1.5 kw       | 2.2 kw         | 3.0 kw         | 4.0 kw         |
| Disc Diameter  | 30cm            | 50cm         | 70cm           | 90cm           | 110cm          |
| Disc Thickness | 26cm × 2        |              |                |                |                |
| Disc Materials | Natural Granite |              |                |                |                |
| Matcha Size    | ≤0.025mm        |              |                |                |                |
| Capacity       | 4 kg/h          | 11 kg/h      | 15 kg/h        | 23 kg/h        | 30 kg/h        |
| Price          |                 |              |                |                |                |



## Tea Blending Mixing Machine (Customized 50kg to 5000kgs)



# 茶叶包装设备

## TEA PACKAGING EQUIPMENTS

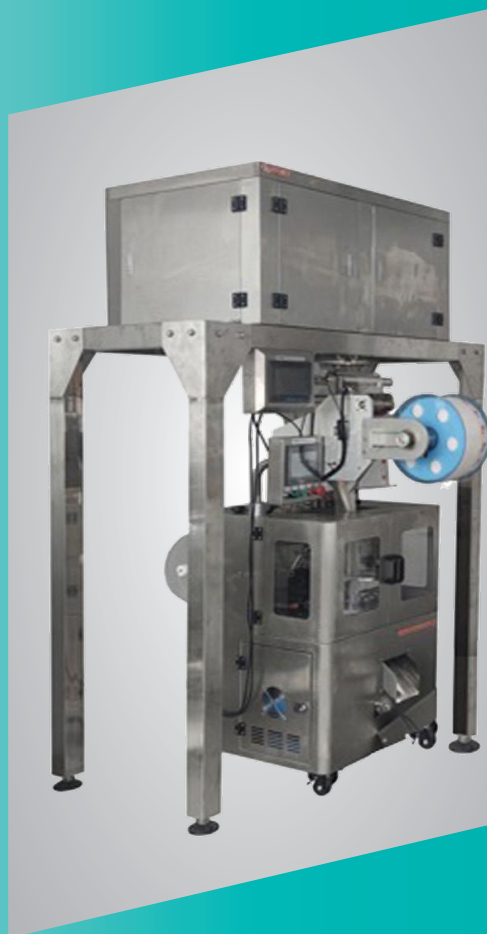

## Small Size Automatic Filling & Sealing Machine

| Model                     | DL-XSBF-D                      | DL-XBF-D     |
|---------------------------|--------------------------------|--------------|
| Operating Voltage         | 110V / 220V                    |              |
| Power                     | 800W                           |              |
| Weighing type             | Vibration                      |              |
| Weighing range            | 1-100 gram                     |              |
| Weighing error            | 0.2 gram                       |              |
| Film Roll Width           | 5-20 cm                        |              |
| Bag Width                 | 2.5-10 cm                      |              |
| Bag Length                | 1-16 cm                        |              |
| Bag Materials             | Nylon / Plastic / Filter Paper |              |
| Sealing Type              | Heat Sealing                   |              |
| Power source              | Electric                       |              |
| Packing Speed             | 10-30 bags/minute              |              |
| Top Filling Machine Size  | 48×48×62cm 32kgs               |              |
| Down Sealing Machine Size | 58×49×103cm 57 kgs             |              |
| Sealing Type              | 3-Side Sealing                 | Back Sealing |
| Price                     |                                |              |



## Middle Size Automatic Filling & Sealing Machine

| Model                     | DL-ZSBF-D                      | DL-ZBF-D     |
|---------------------------|--------------------------------|--------------|
| Operating Voltage         | 110V / 220V                    |              |
| Power                     | 800W                           |              |
| Weighing type             | Vibration                      |              |
| Weighing Range            | 1-500 gram                     |              |
| Weighing error            | 0.2-1 gram                     |              |
| Film Roll Width           | 5-35 cm                        |              |
| Bag Width                 | 2.5-17.5 cm                    |              |
| Bag Length                | 1-23 cm                        |              |
| Bag Materials             | Nylon / Plastic / Filter Paper |              |
| Sealing Type              | Heat Sealing                   |              |
| Power source              | Electric                       |              |
| Packing Speed             | 10-30 bags/minute              |              |
| Top Filling Machine Size  | 30×46×84cm 40kgs               |              |
| Down Sealing Machine Size | 42×50×157cm 85kgs              |              |
| Sealing Type              | 3-Side Sealing                 | Back Sealing |
| Price                     |                                |              |



## Optional Accessories (Functions)



Crusor Sensor



Date/Code Printer



Bag Chain



Inject N2 (Air)

## Tea Weighting & Filling Machine

| Model             | DL-FZ-20               | DL-FZ-100   | DL-FZ-200   | DL-FZ-500   |
|-------------------|------------------------|-------------|-------------|-------------|
| Operating Voltage | 110V / 220V            |             |             |             |
| Power             | 350W                   |             |             |             |
| Hopper Volume     | 4.5-6.5 L              |             |             |             |
| Weighing type     | Vibration Disc / Plate |             |             |             |
| Weighing range    | 1-20 g                 | 1-100 g     | 1-200 g     | 1-500 g     |
| Weighing error    | ±0.2 g                 | ±0.2 g      | ±0.2 g      | ±1 g        |
| Dimensions        | 48×48×62 cm            | 48×48×62 cm | 48×48×62 cm | 48×48×62 cm |
| Machine weight    | 32 kgs                 | 32 kgs      | 32 kgs      | 32 kgs      |
| Price             |                        |             |             |             |



## Hidden Tea Cup Sealing Machine

| Model                | DL-DYCB-8C       |
|----------------------|------------------|
| Dimension            | 430×460×580 mm   |
| Voltage              | 220V 50Hz        |
| Power                | 500 W            |
| Suggest Cup Diameter | ≈80 mm           |
| Suggest Cup Height   | ≈94 mm           |
| Filter Materials     | Non-Woven Fabric |
| Filter Diameter      | 80 mm            |
| Tea Filling Quantity | 2-5 gram         |
| Capacity             | 600 cups/hour    |
| Price                |                  |



## Continuous Sealing Machine With Coder

| Model          | DL-6CFR-900   |
|----------------|---------------|
| Size           | 60×35×32cm    |
| Power          | 500W          |
| Sealing Speed  | 0-12 m/minute |
| Sealing Width  | 6-12mm        |
| Sealing Temp   | 30-300°C      |
| Sealing Length | Unlimited     |
| Print Quantity | ≤39 words     |
| Weight         | 15kgs         |
| Price          |               |



## Vacuuming And Sealing Machine

| Model                 | DL-6CZK-320      | DL-6CZK-420 | DL-6CZK-520 | DL-6CZK-620 |
|-----------------------|------------------|-------------|-------------|-------------|
| Dimension             | 54×44×82 cm      | 64×61×83 cm | 77×73×86 cm | 86×84×88 cm |
| Voltage               | 220V 50Hz        |             |             |             |
| Heating element       | Heating Wire     |             |             |             |
| Maximum vacuum        | 0.08 Mpa         |             |             |             |
| Effective vacuum size | 32×16×26 cm      | 40×44×12 cm | 50×54×12 cm | 60×64×12 cm |
| Sealer Length         | 320 mm           | 420 mm      | 520 mm      | 620 mm      |
| Sealer Width          | 5-10 mm          |             |             |             |
| Sealer Quantity       | 2 pcs            |             |             |             |
| Capacity              | 60-100 bags/hour |             |             |             |
| Price                 |                  |             |             |             |



## Dip Tea Bag Packaging Machine (Only Tea Bag)

|                  |                 |                              |                      |
|------------------|-----------------|------------------------------|----------------------|
| Model            | DL-LSDP         | Packaging Speed              | 30-100 Bags/Minute   |
| Dimension        | 900×750×1750 mm | Weighing Method              | Measure Cup          |
| Voltage          | 220V 50Hz       | Bag Type Which Can Be Packed | Inner Bag ✓          |
| Power            | 1.6 kw          |                              | With Cotton String × |
| Weighting Range  | 1-60g (6-50ml)  |                              | With Tag/Label ×     |
| Inner Bag Length | 70-150mm        | Price                        | Outer Envelop Bag ×  |
| Inner Bag Width  | 30-110mm        |                              |                      |



## Dip Tea Bag Packaging Machine (Bag With String)

|                  |                  |                              |                      |
|------------------|------------------|------------------------------|----------------------|
| Model            | DL-LSDP-X        | Packaging Speed              | 40-60 Bags/Minute    |
| Dimension        | 900×750×1750 mm  | Weighing Method              | Measure Cup          |
| Voltage          | 220V 50Hz        | Bag Type Which Can Be Packed | Inner Bag ✓          |
| Power            | 1.6 kw           |                              | With Cotton String ✓ |
| Weighting Range  | 1-10g (0.6-26ml) |                              | With Tag/Label ×     |
| Inner Bag Length | 50-80mm          | Price                        | Outer Envelop Bag ×  |
| Inner Bag Width  | 45-80mm          |                              |                      |



## Dip Tea Bag Packaging Machine (Bag With String & Tag/Label)

|                  |                  |                              |                      |
|------------------|------------------|------------------------------|----------------------|
| Model            | DL-LSDP-XB       | Packaging Speed              | 40-60 Bags/Minute    |
| Dimension        | 800×700×1800 mm  | Weighing Method              | Measure Cup          |
| Voltage          | 220V 50Hz        | Bag Type Which Can Be Packed | Inner Bag ✓          |
| Power            | 1.6 kw           |                              | With Cotton String ✓ |
| Weighting Range  | 1-10g (0.6-26ml) |                              | With Tag/Label ✓     |
| Inner Bag Length | 40-100mm         | Price                        | Outer Envelop Bag ×  |
| Inner Bag Width  | 45-75mm          |                              |                      |



## Dip Tea Bag Packaging Machine (Bag With String & Tag & Envelop Bag)

|                          |                  |                              |                      |
|--------------------------|------------------|------------------------------|----------------------|
| Model                    | DL-LSDP-XBW      | Outer Envelop Bag Width      | 75-95mm              |
| Dimension                | 1750×740×1950 mm | Packaging Speed              | 30-50 Bags/Minute    |
| Voltage                  | 220V 50Hz        | Weighing Method              | Measure Cup          |
| Power                    | 1.6 kw           | Bag Type Which Can Be Packed | Inner Bag ✓          |
| Weighting Range          | 1-10g (0.6-26ml) |                              | With Cotton String ✓ |
| Inner Bag Length         | 40-100mm         |                              | With Tag/Label ✓     |
| Inner Bag Width          | 45-75mm          | Price                        | Outer Envelop Bag ✓  |
| Outer Envelop Bag Length | 80-120mm         |                              |                      |



## Dip Tea Bag Packaging Materials Information

| Name              | Materials        | 1 Unit Capacity     | Unit Price |
|-------------------|------------------|---------------------|------------|
| Inner Bag         | Filter Paper     | 1 kg = 3500 bags    |            |
|                   | Non-Woven Fabric | 1 kg = 3500 bags    |            |
| String            | Cotton           | 1 roll = 10000 bags |            |
| Tag/Label         | Laminated Paper  | 1 kg = 1600 bags    |            |
| Outer Envelop Bag | PET Film         | 1 kg = 900 bags     |            |

## Pyramid/Triangle Tea Bag Packing Machine (Without Envelop Bag)

|                        |                      |
|------------------------|----------------------|
| Model                  | DL-SJB-4C            |
| Dimension              | 390×160×180 cm       |
| Voltage                | 220V 50Hz            |
| Bag Roll Width         | 12/14/16 cm          |
| Bag Roll Diameter      | 40 cm                |
| Bag Width              | 5/6/7 cm             |
| Request Air Pressure   | 0.6 Mpa              |
| Power                  | 0.8 kw               |
| Packaging Weight Range | 1-15 g               |
| Packaging Speed        | 2000-4500 Bags/hour  |
| Scale Quantity         | 4 / 6 Scales         |
| Bag Type               | Pyramid / Square Bag |
| Price                  |                      |



## Pyramid/Triangle Tea Bag Packing Machine (With Envelop Bag)

|                        |   |
|------------------------|---|
| Model                  | DL-SJB-4CW                              |
| Dimension              | 160×160×180 cm                          |
| Voltage                | 220V 50Hz                               |
| Bag Roll Width         | 12/14/16 cm                             |
| Bag Roll Diameter      | 40 cm                                   |
| Bag Width              | 5/6/7 cm                                |
| Envelop Bag Roll Width | 16-20cm                                 |
| Envelop Bag Width      | 8-10cm                                  |
| Envelop Bag Length     | 8-12cm                                  |
| Request Air Pressure   | 0.6 Mpa                                 |
| Power                  | 0.8 kw                                  |
| Packaging Weight Range | 1-15 g                                  |
| Packaging Speed        | 2000-4500 Bags/hour                     |
| Scale Quantity         | 4 / 6 Scales                            |
| Bag Type               | Pyramid / Square Bag, With Envelop Bags |
| Price                  |   |



## Pyramid Tea Bag Packaging Materials Information

| Name                       | Materials                  | 1 Unit Capacity    | Unit Price |
|----------------------------|----------------------------|--------------------|------------|
| Pyramid Bag Roll           | Nylon                      | 1 Roll = 6000 Bags |            |
|                            | Corn Fiber (Biodegradable) | 1 Roll = 6000 Bags |            |
| Envelop Bag Roll           | PET Film                   | 1 kg = 900 bags    |            |
| Envelop Bag (Pre-Made Bag) | PET Film                   | MOQ 1000 pcs       |            |
| Outer Envelop Bag          | PET Film                   | 1 kg = 900 bags    |            |

# TEA PRELIMINARY PROCESSING PRODUCTION LINE

## 茶叶初加工生产线



▲ AUTO TEA STORAGE MACHINE



▲ SUNSHINE TEA WITHERING LINE



▲ AUTO TEA WITHERING TROUGH



▲ AUTO TEA WITHERING GROUP



▲ HIGH TEMP HOT AIR FIXATION LINE



▲ ELECTRIC TEA FIXATION LINE



▲ AUTO FEED & DISCHARGE TEA ROASTER LINE

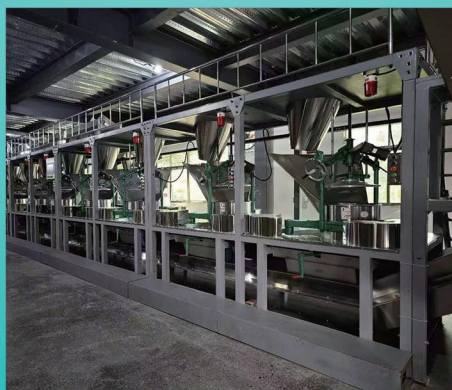

▲ AUTO TEA ROLLING GROUP



▲ CHAIN PLATE TEA DRYER

# BULK TEA AUTOMATIC SORTING AND REFINING LINE

新茶饮精制自动生产线（分级、除杂、匀堆）



▲ AUTO TEA SORTING CLEANING LINE



▲ AUTO TEA SORTING CLEANING BLENDING LINE



▲ AUTOMATIC TEA BLENDING MIXING LINE



▲ ROTATE TEA BLENDING FRAGRANCE MACHINE



▲ TEA PACKAGE METAL DETECTION AND WEIGHT DETECTION LINE

# TEA AUTOMATED PACKAGING PRODUCTION LINE SERIES

## 茶叶自动化包装生产线系列



▲ TEA WEIGHING & FILLING LINE



▲ AUTO FEEDING TEA POUCH  
PACKING LINE



▲ TEA POUCH PACKAGING LINE

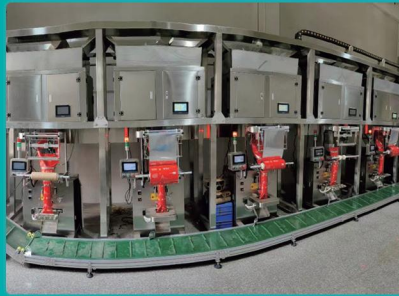

▲ TEA POUCH PACKAGING LINE



▲ TEA POUCH PACKAGING LINE



▲ TEA POUCH PACKAGING LINE



▲ AUTO FEEDING TEA POUCH  
PACKAGING LINE



▲ DIP TEA BAG LINE



▲ BULK TEA BLENDING  
PACKAGING LINE

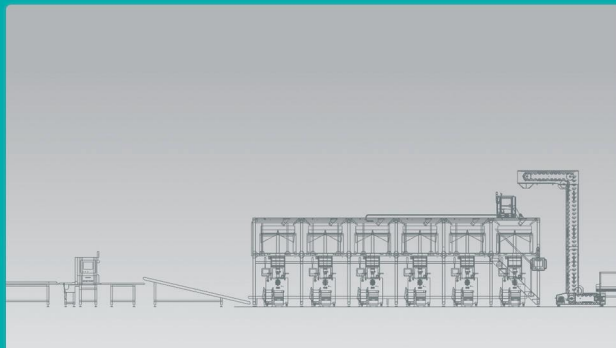

▲ TEA POUCH METAL DETECTION LINE

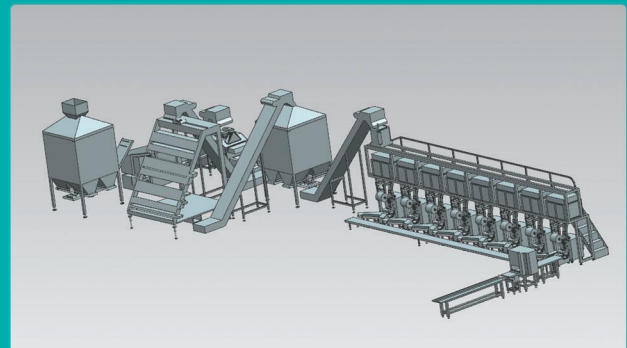

▲ TEA BLENDING & PACKAGING LINE

泉州得力农林机械有限公司

## 泉州得力农林机械有限公司

Quanzhou Deli Agroforestral Machinery Co., Ltd

地址: 福建省安溪县城厢镇德苑工贸园冬兴路12号

ADD: Dongxing District, Deyuan Industrial And Trade Zone,  
Anxi County, Fujian Province

TEL : +86-18120033767

Website: [www.delijx.com](http://www.delijx.com)

Email : [info@delijx.com](mailto:info@delijx.com)

WhatsApp / WeChat / Telegram: +86-18120033767